



EDGE Evolution 1 Fixture



- Grid Installation 2
- FL-Inaccessible Installation 3-4
- NF-Inaccessible Installation 5-6
- Spackle Flange Inaccessible Installation 7
- Perimeter Mount 8-9
- Rotating Crossbar - Inaccessible Installation 10
- Connector Details 11-15
- Field Cut Illuminated Extension Installation 16-20
- Lens Detail 21
- Veil Louver Detail 22-24

DISCLAIMERS

*All of Pinnacle's packaging is recyclable with the exception of the straps on the pallets. Please reach out to the factory if you need assistance in recycling any packaging components.
 A carbide tipped saw blade for aluminum is recommended for cutting the extension box.
 An AGE MD12-962 Industrial Carbide tipped plastic saw blade is recommended for cutting the lens.
 This product must be installed in accordance with applicable installation and electrical codes by a professional familiar with the construction and operation of the product.*

*Minimum 90° C supply conductor.
 All electrical connections must be performed by a certified electrician to applicable local and national electrical codes.
 Damaged components must never be used.
 Contact Pinnacle prior to making any fixture alterations.
 Contact Pinnacle with any installation questions or field issues.*



1 GRID PREPARATION AND INSTALLATION

Layout fixture and T-bar locations, fixtures require secondary mains along the length of the row, both sides. Layout and install junction boxes. Lay first fixture into grid. Tie off fixture to structure.
(Note: Asymmetric lens option will have sticker on lens indicating wall side)

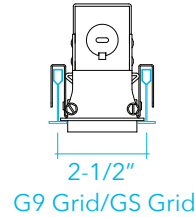
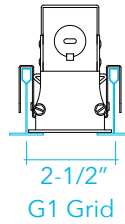
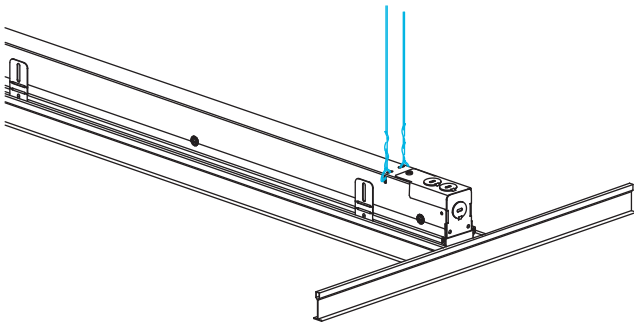

2 POWER

Remove Access Plate via one screw. Make wiring connections to building power and replace Access Plate.

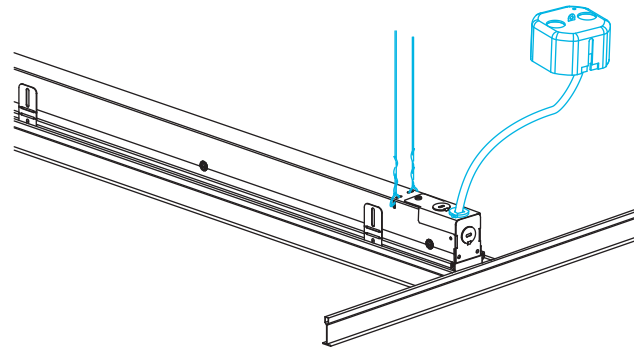

3 JOINING

Make wiring connections between fixtures, tap joining biscuits (2) in to one fixture, slide fixtures together, and secure using joining bracket and supplies #8-32 screws (2).

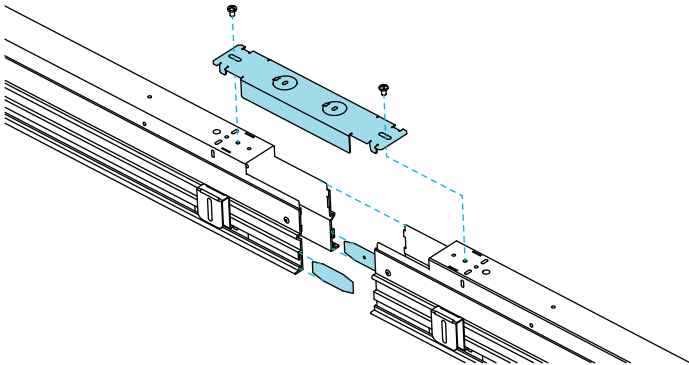

4 SECURING TO GRID

Center fixture on grid, bend grid brackets over and fasten to grid.

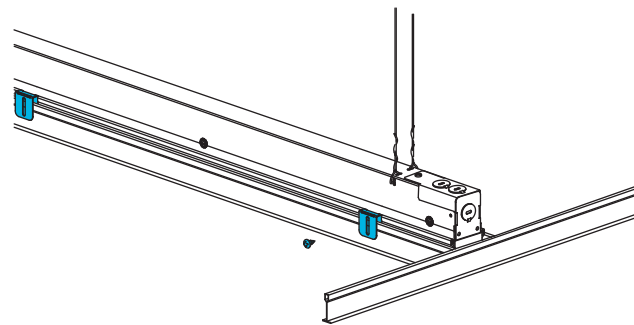



1 LAYOUT & DIMENSIONS

Rough in fixture opening and install 1/4" hardware (by others) according to tables to the right. Fixture length can be found on label inside fixture.

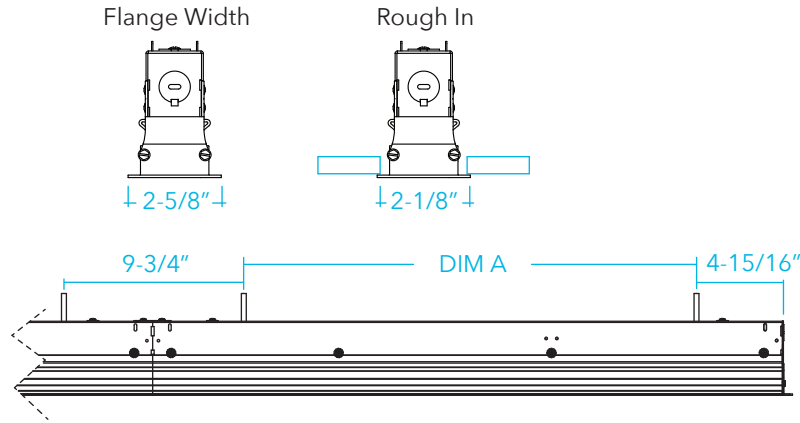

NOTE: Rough-in for length is Row or Fixture Length + 3/8"

THREADED ROD LOCATIONS

LENGTH	DIM A
23"	13-1/4"
24"	14-1/4"
35"	25-1/4"
36"	26-1/4"
47"	37-1/4"
48"	38"-1/4"
59"	49-1/4"
60"	50-1/4"
71"	61-1/4"
72"	62-1/4"
83"	73-1/4"
84"	72-1/4"
95"	85-1/4"
96"	86-1/4"

2 POWER

Remove Access Cover via one screw. Attach conduit to access cover using 1/2" trade fittings. Make wiring connections to building power and replace Access Cover.

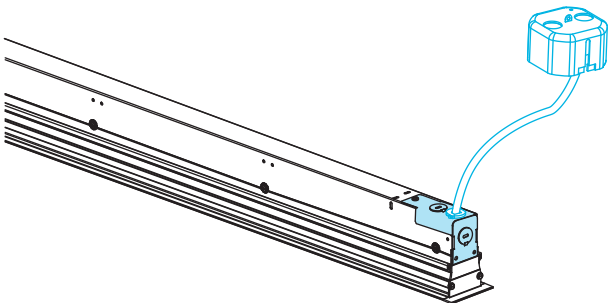

3 INDIVIDUAL OR BEGINNING OF RUN FIXTURE

Carefully remove lens using a putty knife (detail view on pg 11). Remove reflectors via matte black #8-23 screws. Disconnect reflector wiring. Mount fixture through mounting hole to 1/4" hardware (by others).

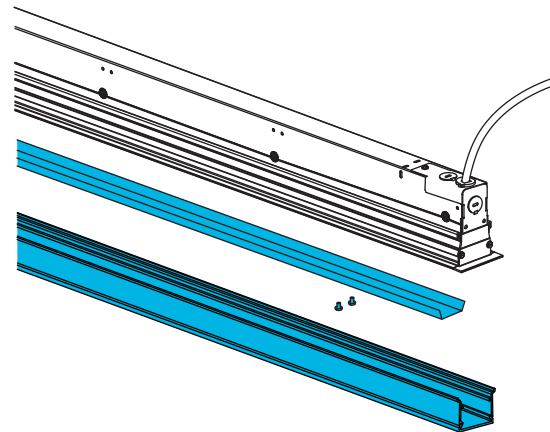



4 JOINING FIXTURES

Remove lens or louver and reflector. Lift and fixture into place mounting fixture through mounting slot using 1/4" hardware (*by others*). Make wiring connections between fixtures, tap joining biscuits (2) in to one fixture, slide fixtures together, and secure using joining bracket and supplies #8-32 screws (2).

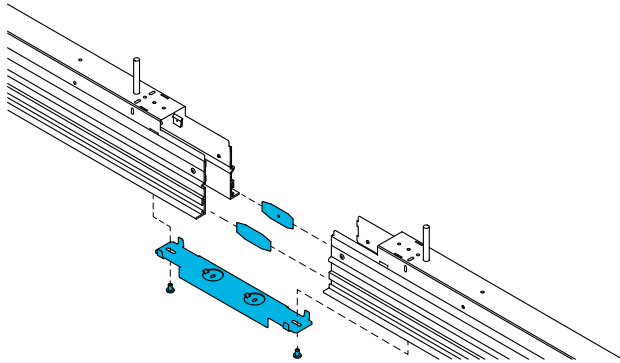

5 FINISHING

Reinstall reflectors and lenses into all fixtures.

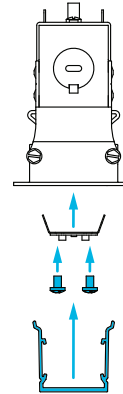



1 LAYOUT & DIMENSIONS

Rough in fixture opening and install 1/4" hardware (by others) according to tables to the right. Fixture length can be found on label inside fixture.

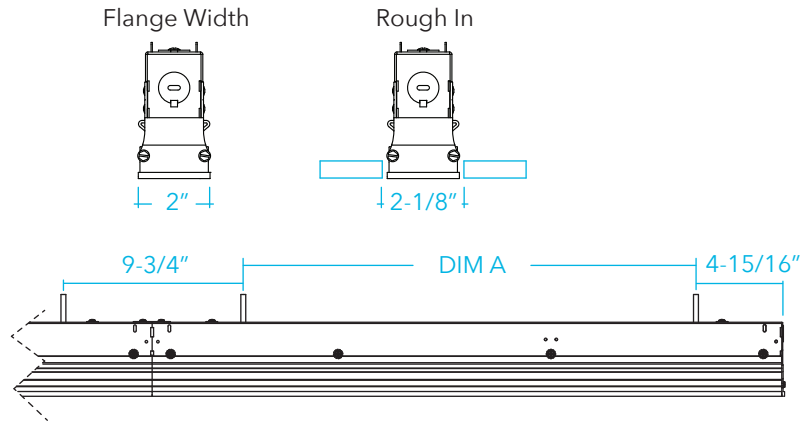

NOTE: Rough-in for length is Row or Fixture Length + 3/8"

THREADED ROD LOCATIONS

LENGTH	DIM A
23"	13-1/4"
24"	14-1/4"
35"	25-1/4"
36"	26-1/4"
47"	37-1/4"
48"	38"-1/4"
59"	49-1/4"
60"	50-1/4"
71"	61-1/4"
72"	62-1/4"
83"	73-1/4"
84"	72-1/4"
95"	85-1/4"
96"	86-1/4"

2 POWER

Remove Access Cover via one screw. Attach conduit to access cover using 1/2" trade fittings. Make wiring connections to building power and replace Access Cover.

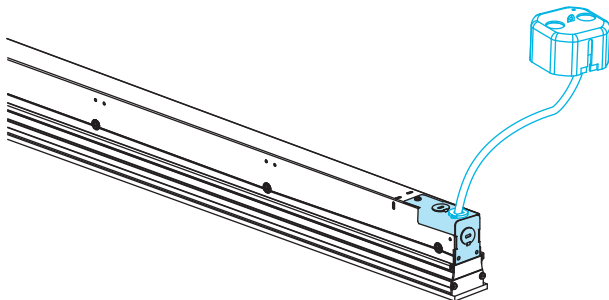

3 INDIVIDUAL OR BEGINNING OF RUN FIXTURE

Carefully remove lens using a putty knife (detail view on pg 11). Remove reflectors via matte black #8-23 screws. Disconnect reflector wiring. Mount fixture through mounting hole to 1/4" hardware (by others).

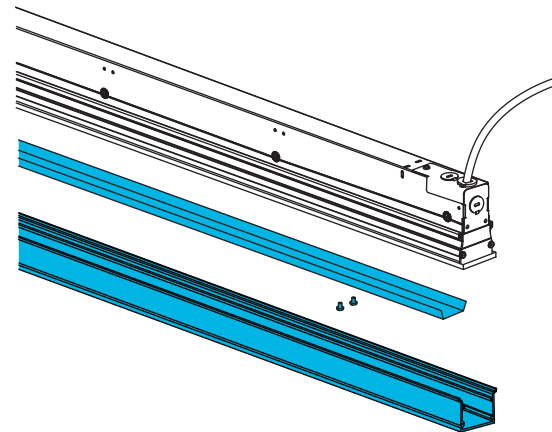



4 JOINING FIXTURES

Remove lens or louver and reflector. Lift and fixture into place mounting fixture through mounting slot using 1/4" hardware (*by others*). Make wiring connections between fixtures, tap joining biscuits (2) in to one fixture, slide fixtures together, and secure using joining bracket and supplies #8-32 screws (2).

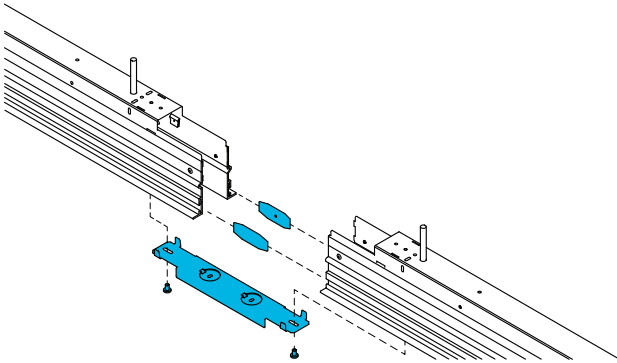

5 FINISHING

Reinstall reflectors and lenses into all fixtures.

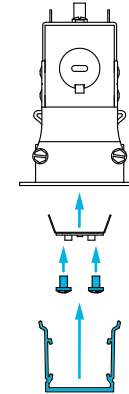



Note: Do not screw in to side of housing. Do not remove cross brackets until fixture is installed.

1 DIMENSIONS AND LAYOUT

Rough in fixture opening, fixture length can be found on label inside fixture.
NOTE: Rough-in for length is Row or Fixture Length + 3/8"

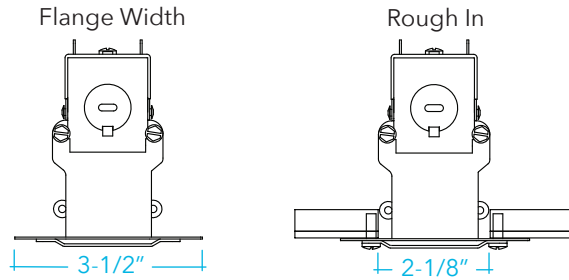

3 INDIVIDUAL OR BEGINNING OF RUN FIXTURE

Mount fixture in rough-in opening using drywall screws placed every foot on both sides, along the length of the fixture/run and two on each end flange. Once mounted, remove cross brackets and discard. If individual fixture install lens.

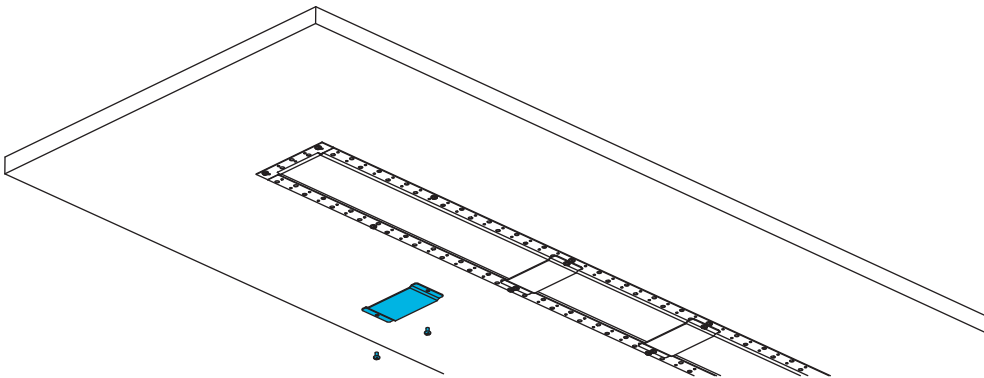

2 POWER

Remove Access Plate via one screw. Make wiring connections to building power and replace Access Plate.

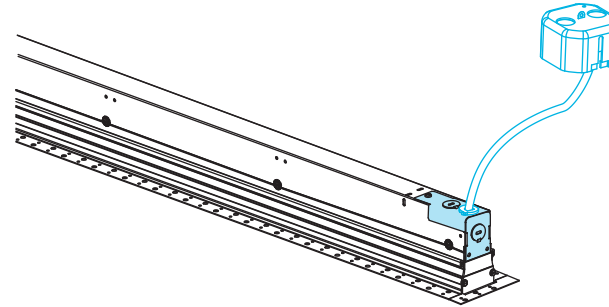

4 JOINING

Install end trims on all non-joining ends. Lift fixture into roughed out opening. Mount fixtures in place by putting a screw in behind each cross bracket along the fixture. Remove reflector by removing matte black #8-32 screws. Join fixtures together using supplied joint bracket and #8-32 screws from inside the fixture. Make wiring connections between fixtures. Once all fixtures in row are installed, reinstall reflectors and install lenses.

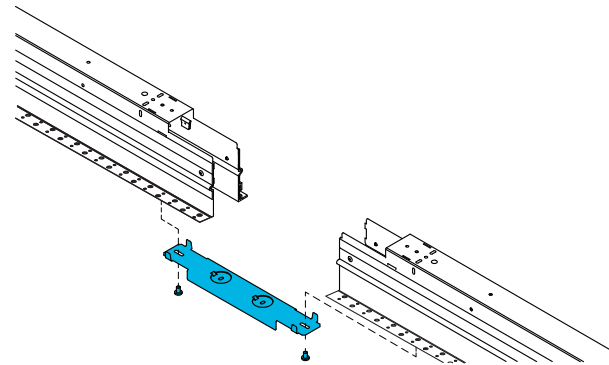



1 LAYOUT & DIMENSIONS

Rough in fixture opening and install 1/4" hardware (by others) according to tables to the right. Fixture length can be found on label inside fixture.

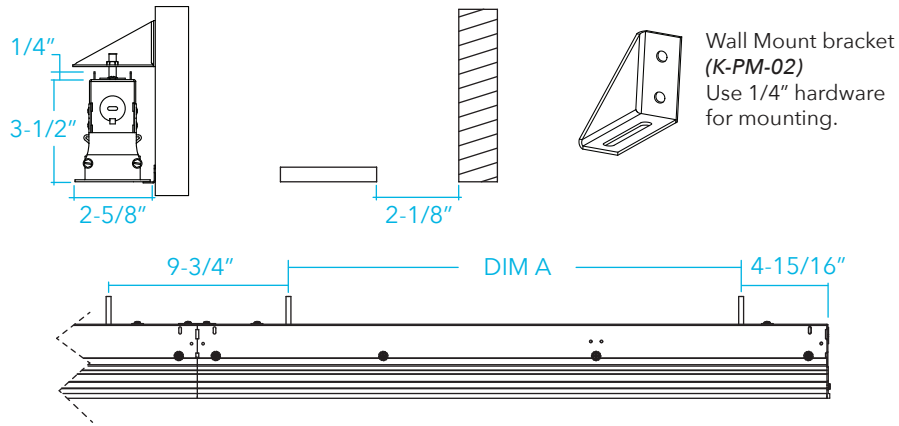

NOTE: Rough-in for length is Row or Fixture Length + 3/8"

THREADED ROD LOCATIONS

LENGTH	DIM A
23"	13-1/4"
24"	14-1/4"
35"	25-1/4"
36"	26-1/4"
47"	37-1/4"
48"	38"-1/4"
59"	49-1/4"
60"	50-1/4"
71"	61-1/4"
72"	62-1/4"
83"	73-1/4"
84"	72-1/4"
95"	85-1/4"
96"	86-1/4"

2 POWER

Remove Access Cover via one screw. Attach conduit to access cover using 1/2" trade fittings. Make wiring connections to building power and replace Access Cover.

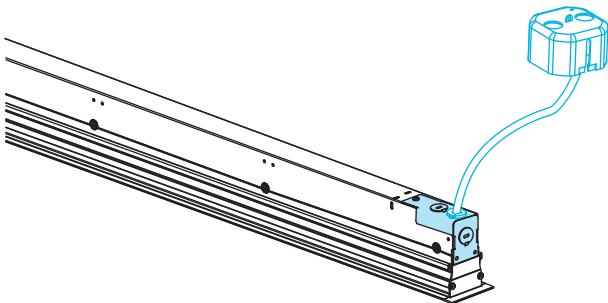

3 INDIVIDUAL OR BEGINNING OF RUN FIXTURE

Carefully remove lens using a putty knife (detail view on pg 11). Remove reflectors via matte black #8-23 screws. Disconnect reflector wiring. Mount fixture through mounting hole to 1/4" hardware (by others).

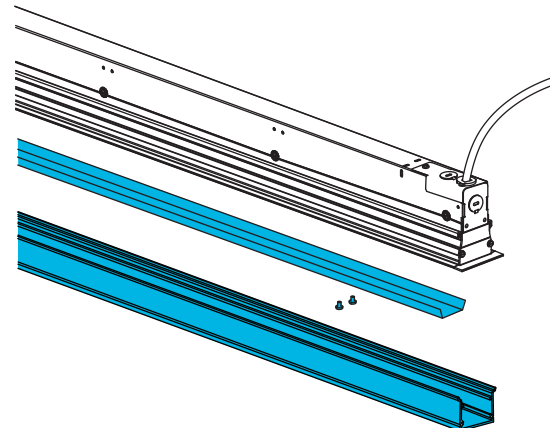



4 JOINING FIXTURES

Remove lens or louver and reflector. Lift and fixture into place mounting fixture through mounting slot using 1/4" hardware (by others). Make wiring connections between fixtures, tap joining biscuits (2) in to one fixture, slide fixtures together, and secure using joining bracket and supplies #8-32 screws (2).

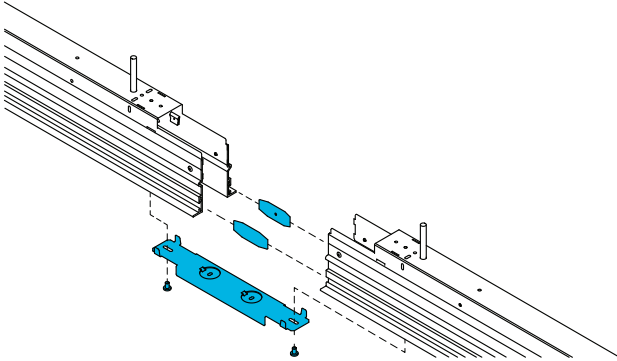

5 FINISHING

Reinstall reflectors and lenses into all fixtures.

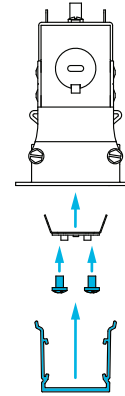



1 LAYOUT & DIMENSIONS

Rough in Fixture opening. Fixture length can be found on fixture label inside fixture.

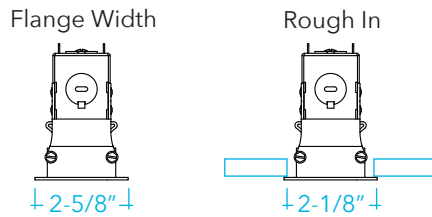

3 INDIVIDUAL FIXTURE

Carefully remove lens using putty knife. Remove reflectors via matte black #8-23 screws. Disconnect reflector wiring. Slide fixture into rough-in opening and rotate crossbar to lock in place using 1/4-20 screw inside fixture. If individual fixture replace reflector and lens (detail view on pg 11). (Note: Lens and reflector differ in shape between aperture sizes.)

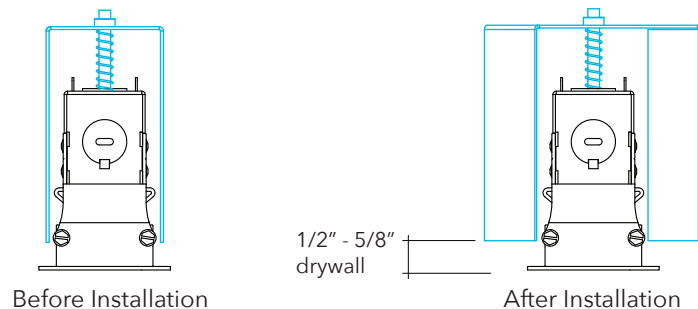

2 POWER

Remove access cover via one screw. Make wiring connections to building power and replace access cover.

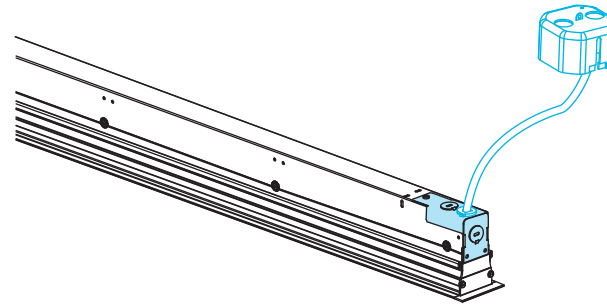

4 JOINING

Make wiring connections between fixtures, tap joining biscuit in to one fixture, slide fixtures together, and secure using joining bracket and four screws. Once all fixtures in row are installed replace reflectors and lenses (detail view on pg 11).

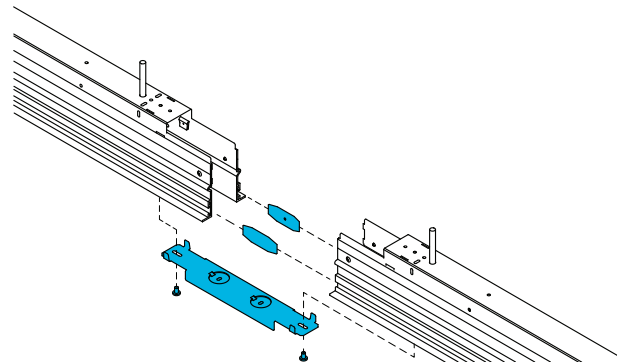



Note: Reference applicable page for specific mounting. IE reference FL instruction page if using FL mounting.

CORNER PIECE

Attach inside corner to Edge Evolution 1 wall section using mounting hardware. Attach Inside Corner electrical cover to Edge Evolution ceiling section using mounting hardware. Install Wall Section and connect Ceiling Section using #8-32x1/2 Screw to fasten Inside Corner Bracket to Inside Corner Electrical Cover. Make Necessary wiring connections to building power.

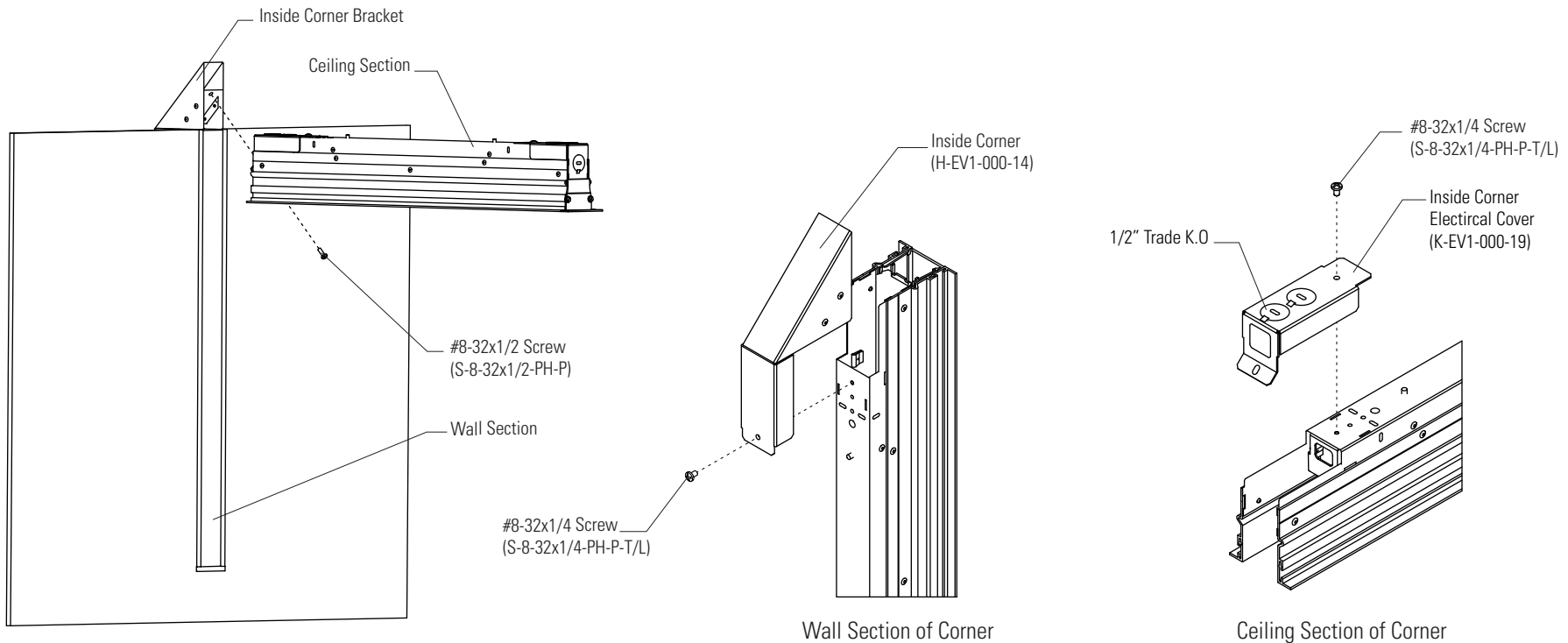



Note: Reference applicable page for specific mounting. IE reference FL instruction page if using FL mounting.

CORNER PIECE

Layout fixture and rough-in location. Fixture requires secondary mains, or blocking along the length of fixture, both sides. (Note: corners are 90°). Corners install same as fixture(s) and are required to be tied to structure. Remove knock out between fixtures and make necessary wiring connections. Join using supplied joining hardware.

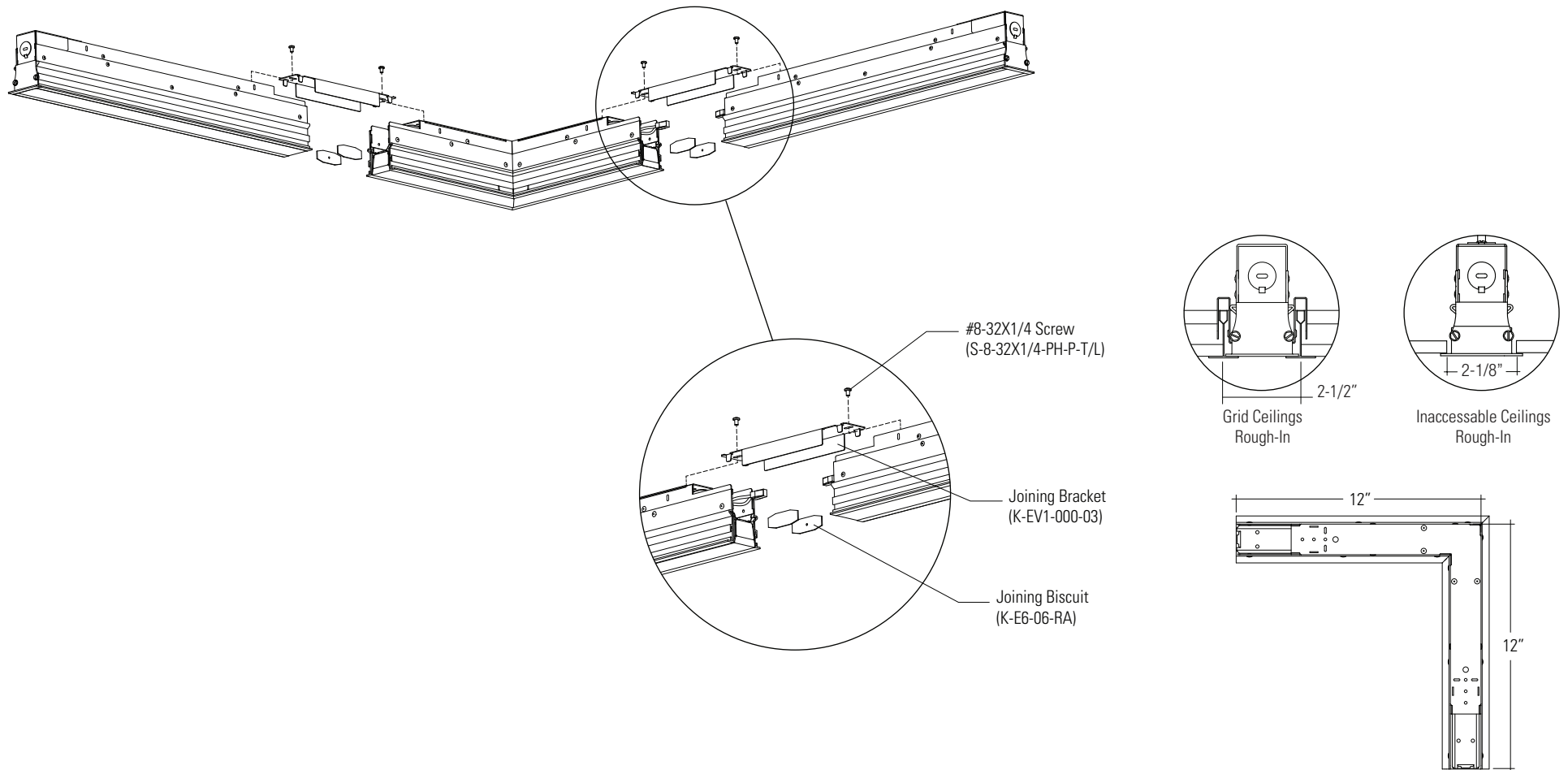



Note: Reference applicable page for specific mounting. IE reference FL instruction page if using FL mounting.

CORNER PIECE

Layout fixture and rough-in location. Fixture requires secondary mains, or blocking along the length of fixture, both sides. (Note: corners are 90°). Corners install same as fixture(s) and are required to be tied to structure. Remove knock out between fixtures and make necessary wiring connections. Join using supplied joining hardware.

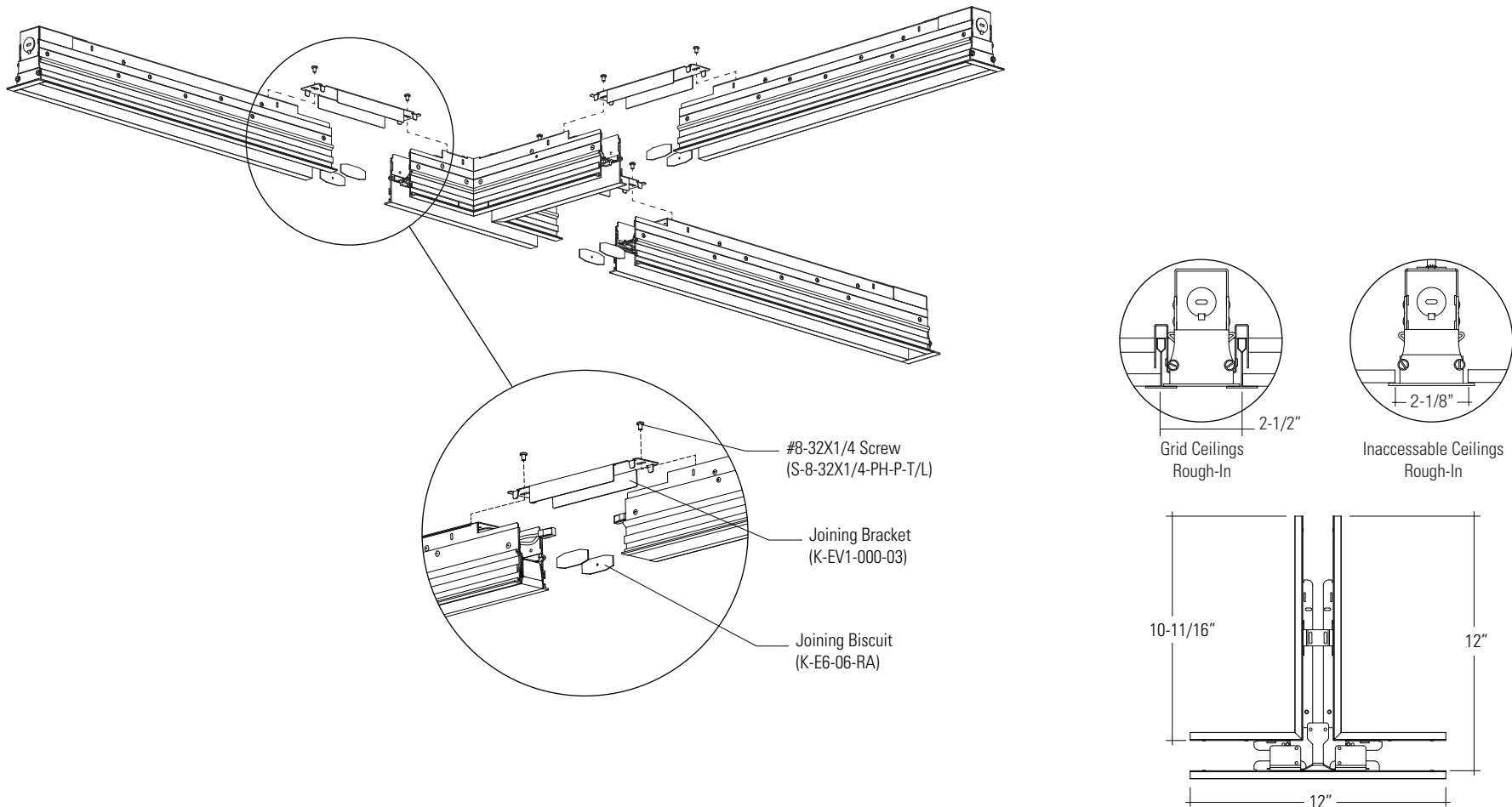



Note: Reference applicable page for specific mounting. IE reference FL instruction page if using FL mounting.

CORNER PIECE

Layout fixture and rough-in location. Fixture requires secondary mains, or blocking along the length of fixture, both sides. (Note: corners are 90°). Corners install same as fixture(s) and are required to be tied to structure. Remove knock out between fixtures and make necessary wiring connections. Join using supplied joining hardware.

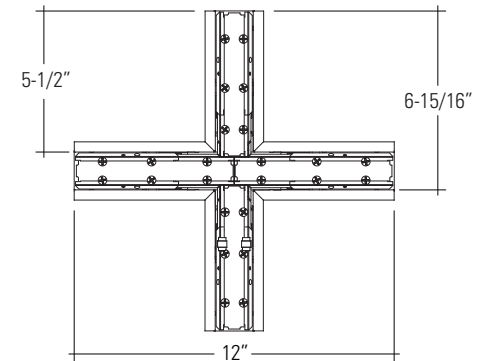
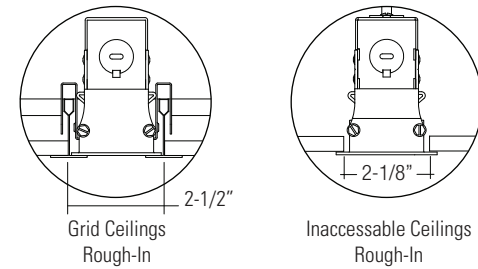
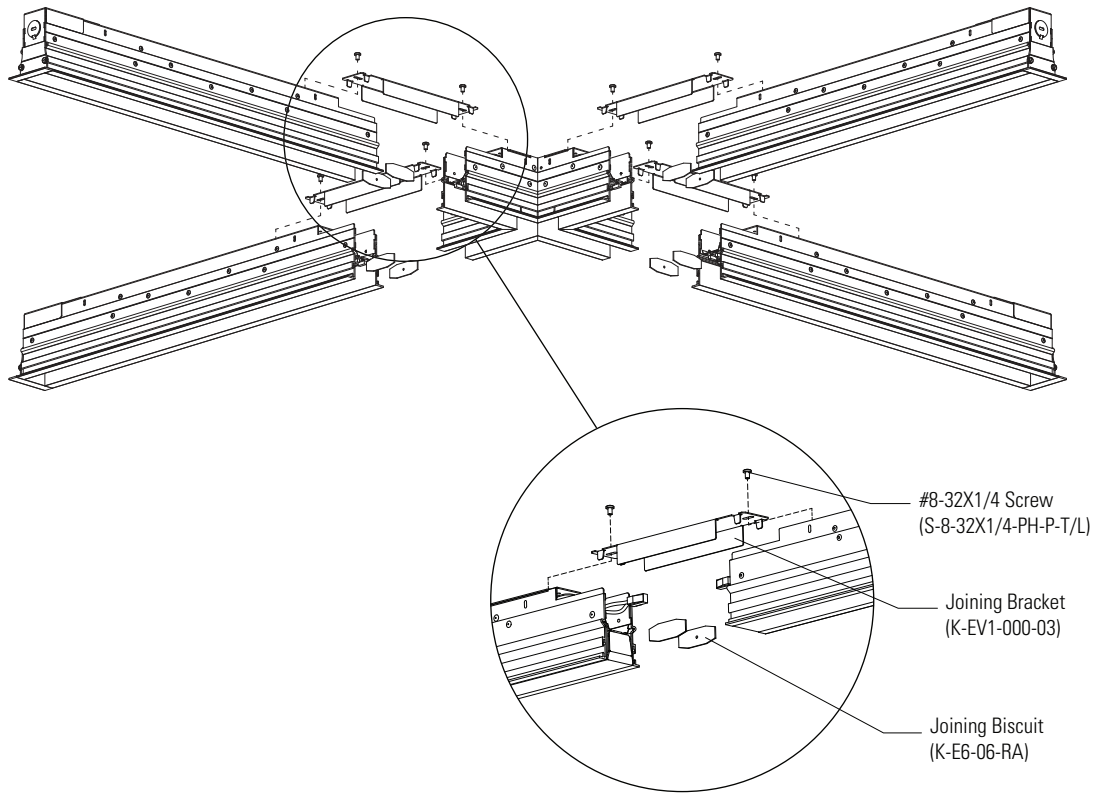



Note: Reference applicable page for specific mounting. IE reference FL instruction page if using FL mounting.

CORNER PIECE

Layout fixture and rough-in location. Fixture requires secondary mains, or blocking along the length of fixture, both sides. (Note: corners are 90°). Corners install same as fixture(s) and are required to be tied to structure. Remove knock out between fixtures and make necessary wiring connections. Join using supplied joining hardware.

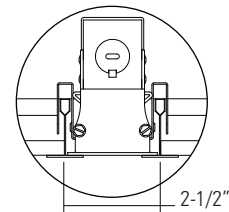
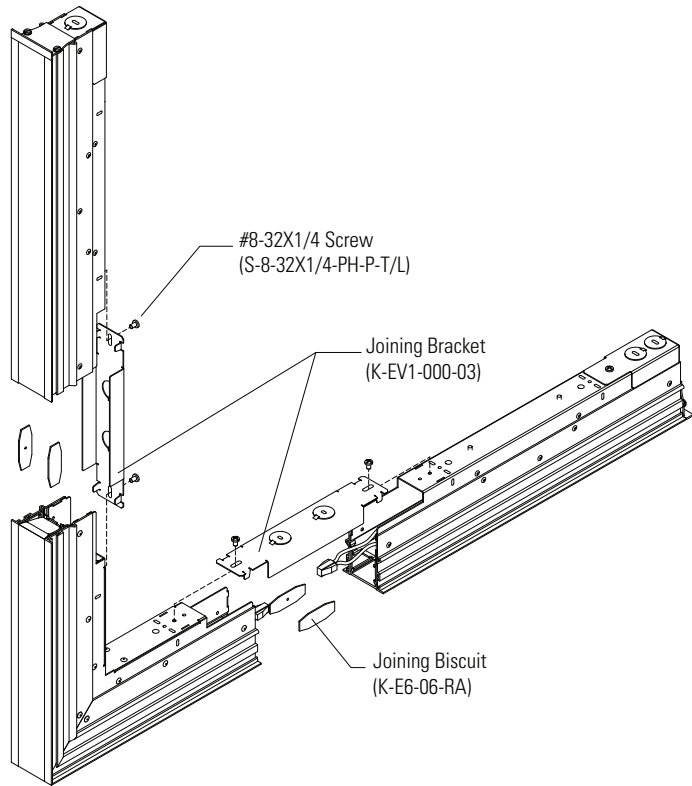

Grid Ceilings
Rough-In

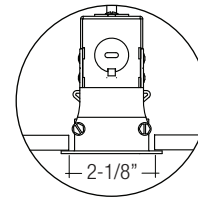

Inaccessible Ceilings
Rough-In

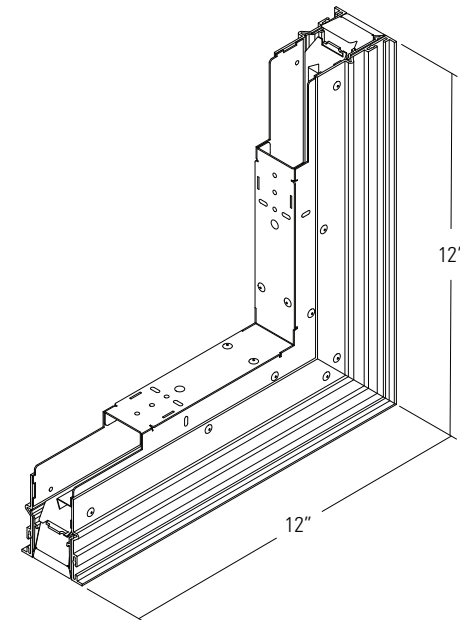



FIELD CUTTABLE EXTENSION UNIT BREAKDOWN

Below are the component pieces required for adjusting and installing the extension. Component pieces are located in the fixture box.

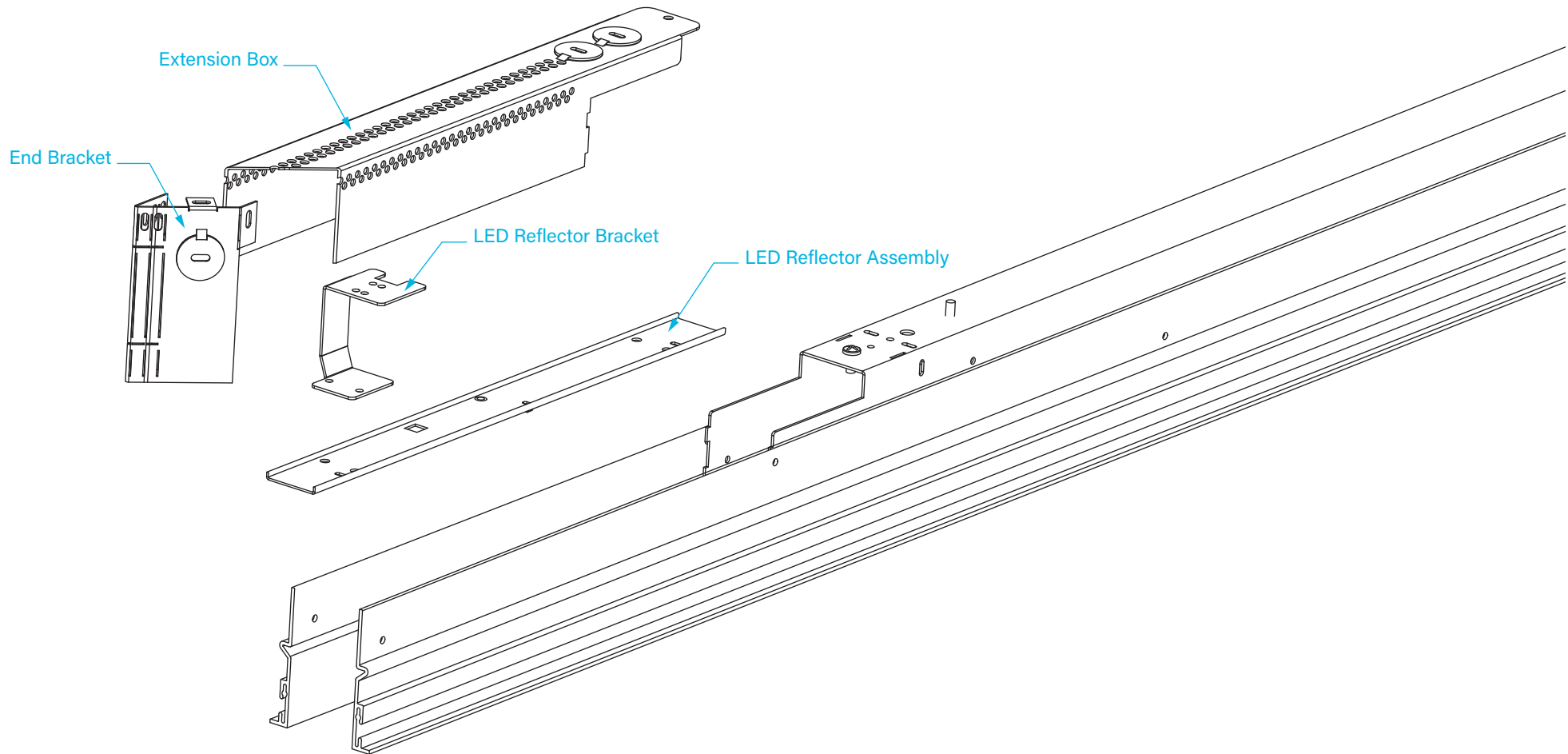



1 EXTENSION BOX PREP

Measure the desired length and angle of the final assembled fixture (Extension Box + Main Fixture). Measure the required length from the end of the extension box. Make sure to measure from the end that attached to the main fixture.

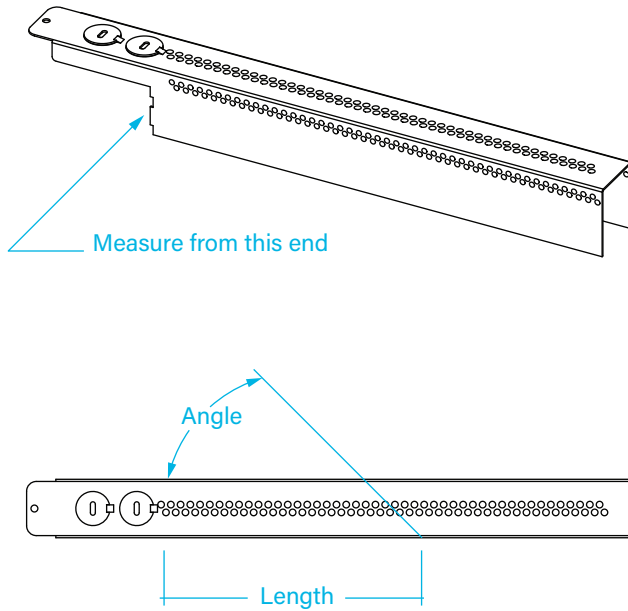

2 END BRACKET SETUP

After cutting the extension box, locate end bracket. Fold the end bracket's tabs to a position that will minimize the gap between the extension box and the end bracket. The additional tabs may be cut if desired.

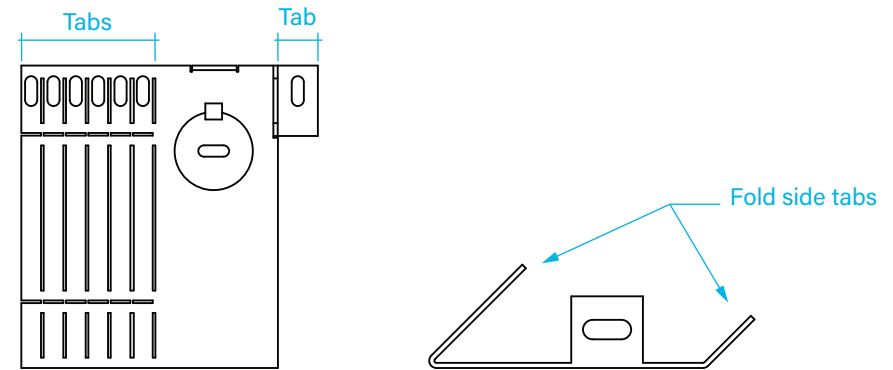



1 EXTENSION BOX ASSEMBLY

Secure the end bracket to the cut end of the extension box. Utilize 3 screws/rivets from kit and place them in the locations as shown below.

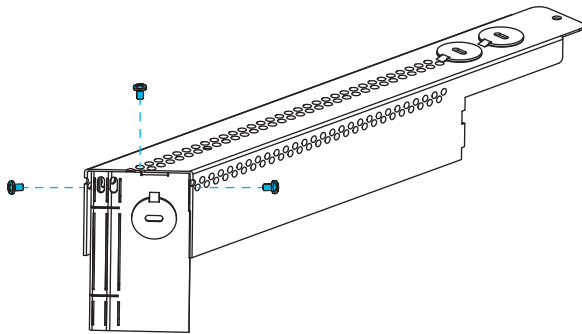

2 LED EXTENSION INSTALLATION

Install the LED board and reflector assembly as shown below using (4) screws/rivets from the kit. Secure the parts in the top row of holes when viewing from a room view perspective. *(note: the LED board in the extension box will sit "above", when viewing from a room side, the main fixture's LED board.)*

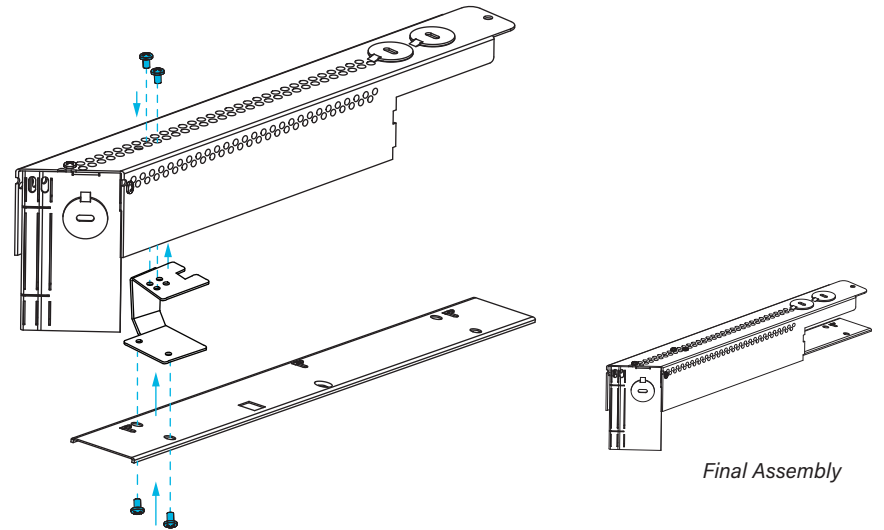

Final Assembly



1 EXTENSION BOX INSTALLATION

Take the illuminated extension and connect the LED wires to the wires protruding from the main fixture. It is recommended to store any excess wiring in extension box. Slide the extension in between the rails and flush with fixture housing secure with screw.

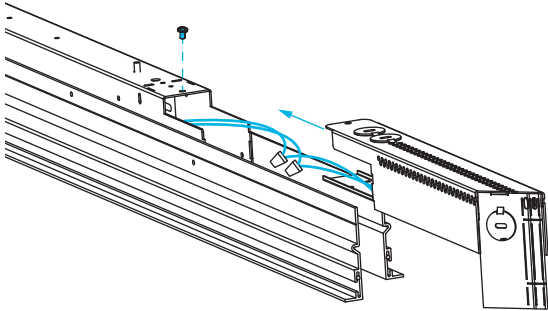

2 RAIL TRIMMING

Once extension is installed to main fixture trim the excess rails to be flush with end of extension.

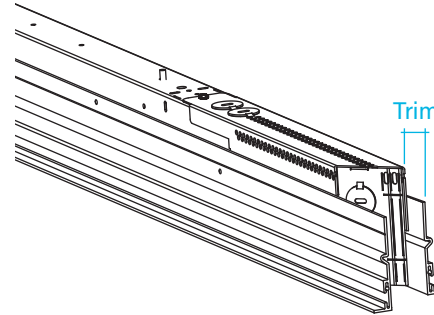



1 TRIM LENS AND INSTALL

Select and measure the desired lens length and angle. The lens included in the kits are longer than required. Lens material expands with the heat of the LED boards. Run the saw at full speed and cut the lens slowly to avoid fracture and/or cracking. To account for this, subtract 1/32" from the total desired fixture length to account for thermal expansion.
(i.e. 96" fixture takes a total or combined lens length of 95.969")

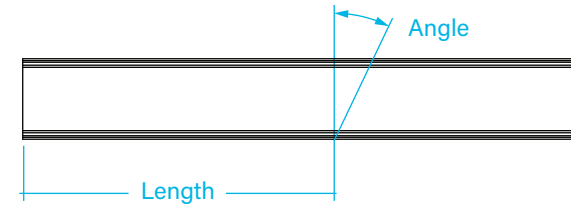
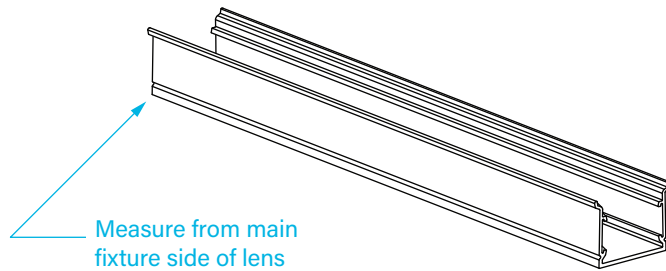



LENS INSTALLATION

Begin at one end of the lens and squeeze sides to allow it to flex. Insert end of lens into place. Lens will snap into place when installed properly. Slowly insert rest of lens down the length of the fixture. Lens will have Internal Light Diffusers (one for each end). Light diffuser fills gaps that might occur because of thermal expansion.

(Note: Asymmetric lens option will have sticker on lens indicating wall side)

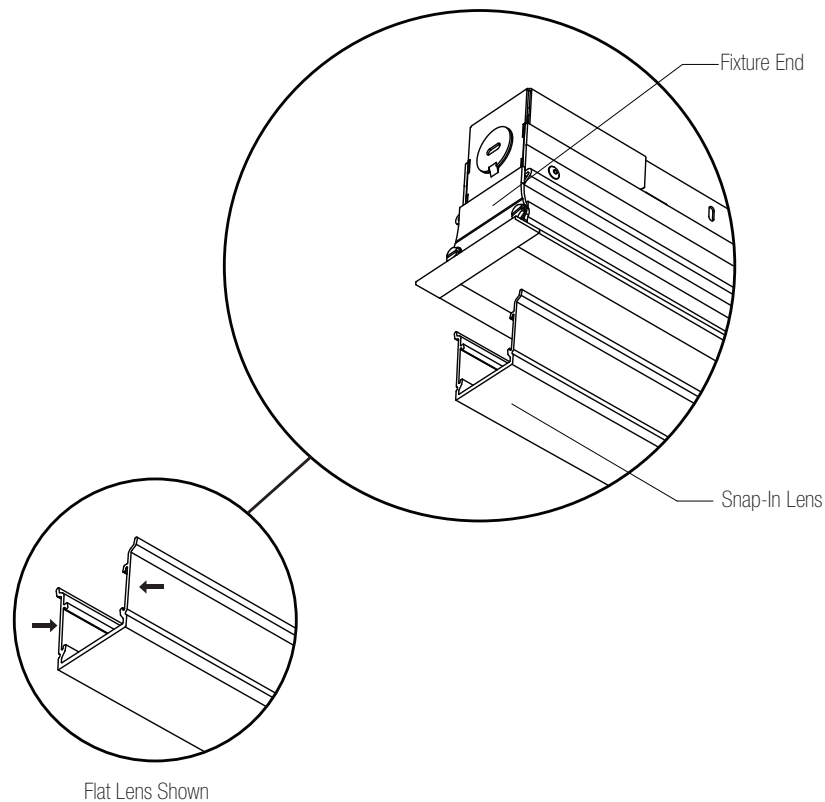

LENS REMOVAL

Insert a rigid object approx. 1/16" thick, such as a putty knife, into the edge between the lens and the fixture side about one inch from end. Using said object, gently pry lens away from fixture until it is released from the mounting edge. Once the section is released, start at that end of the fixture and pull the lens out of the fixture.

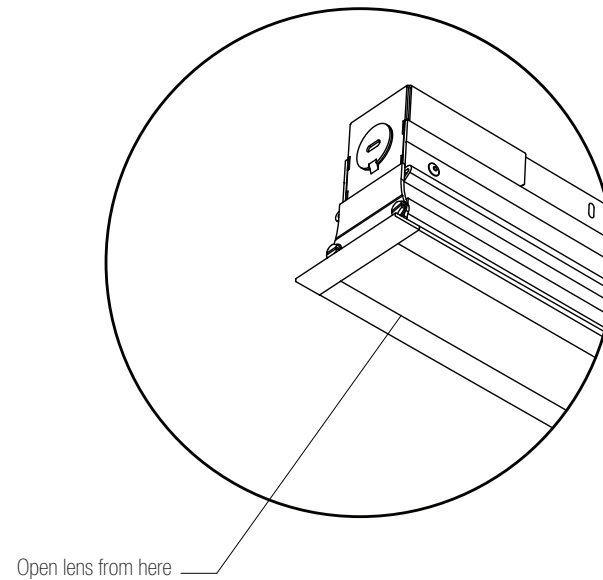

Note: Low temperatures can effect the lens material, making it brittle. Please allow the lenses to warm to room temperature before installation.



1 LOUVER or BLANK INSTALLATION

Reconnect the LED harness to the louver. Align the louver or blank with the opening in the fixture housing, then squeeze the side legs inward while pressing the section straight into place until it snaps securely. Verify that the section is fully seated and flush with the housing before restoring power and confirming proper operation.

Note: In some configurations, a louver or blank section may span across the joint between two fixtures.

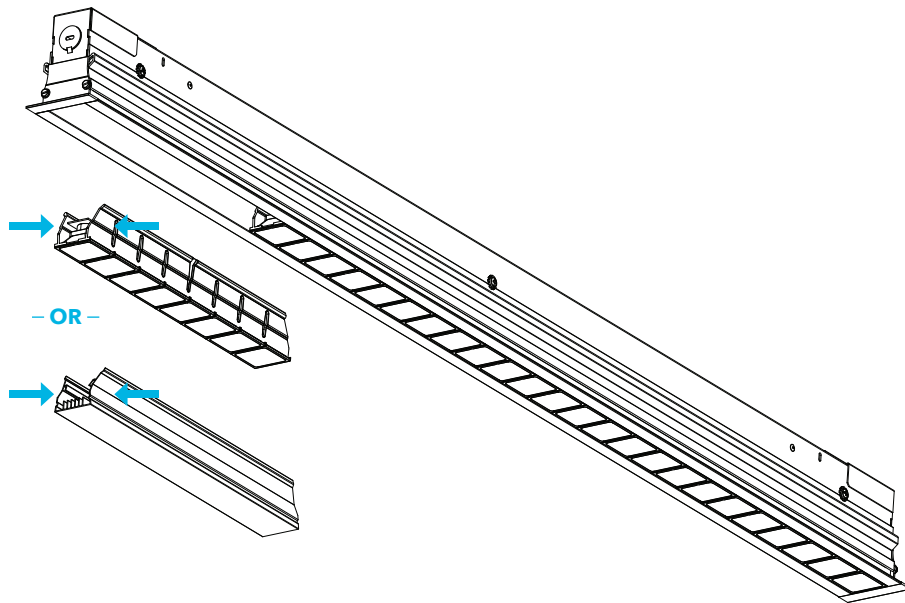

2 LOUVER or BLANK REMOVAL

Before beginning, ensure power to the fixture is turned off. To remove the louver or blank section, insert a flat-head screwdriver either between the module end and the fixture housing or between adjacent modules. Gently twist or pry to release the section from the housing. Once the part is free, disconnect the LED harness (if applicable) and carefully remove the section from the fixture.

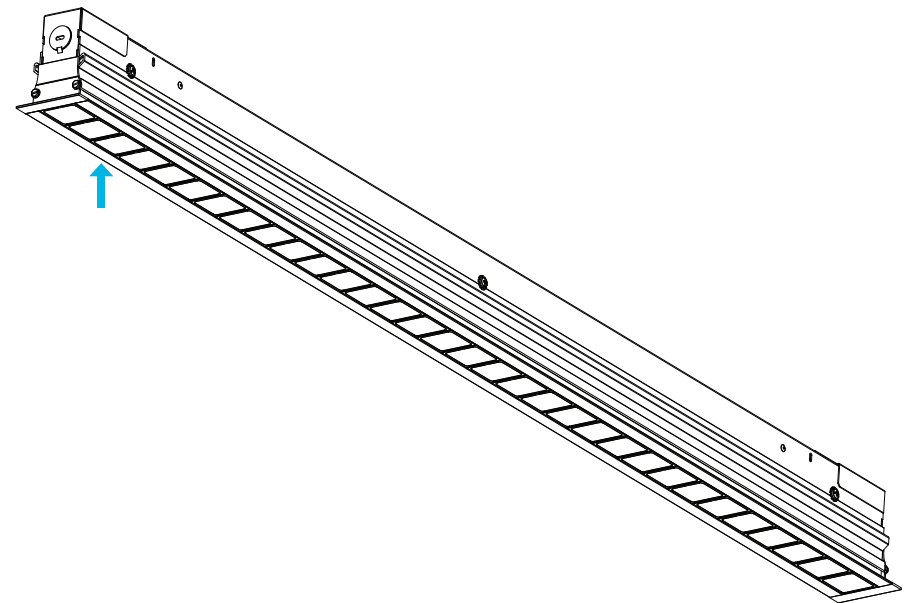



Louver+Lens Individual Unit Breakdowns

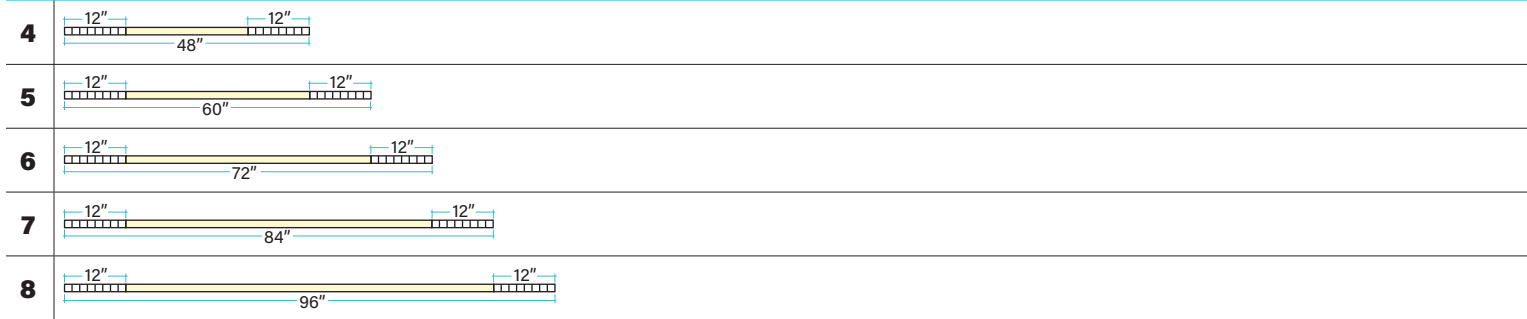

Louver+Lens Continuous Run Breakdowns

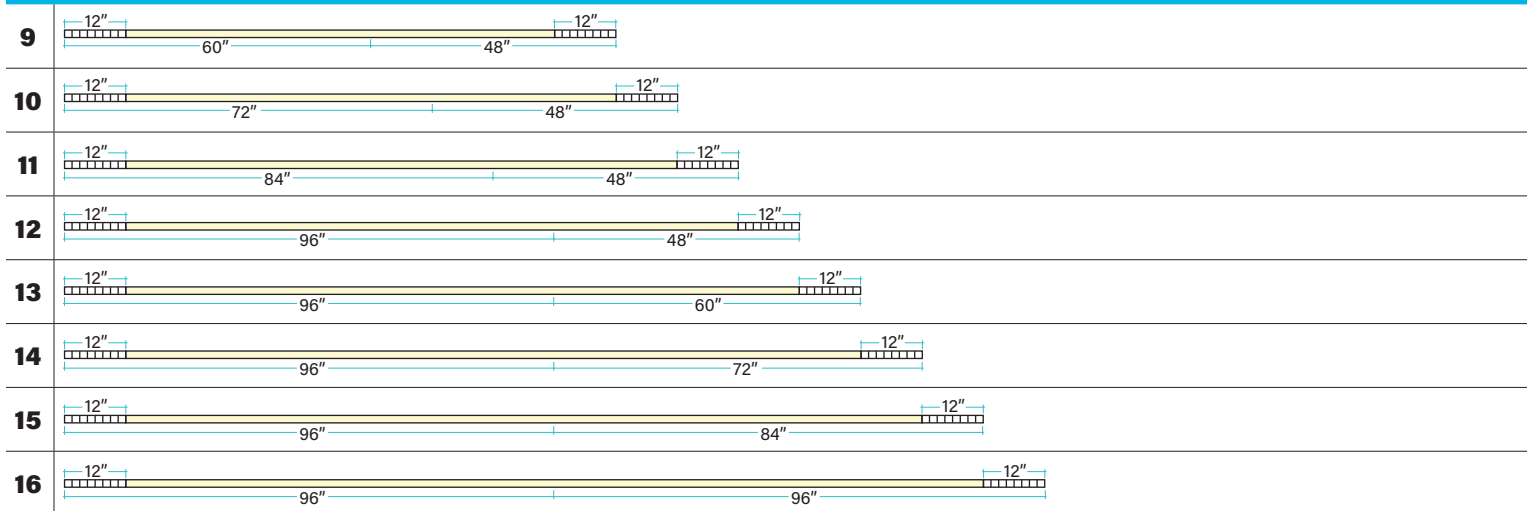

Louver+Blanks Individual Unit Breakdowns





Louver+Blanks Continuous Run Breakdowns

