

EDGE Evolution Outline

INSTALLATION INSTRUCTIONS

Outline Installation	2-5
Outline End Filler Installation	6-9
Outline Outside Corner Installation	10-13
Outline Inside Corner Installation	14-19

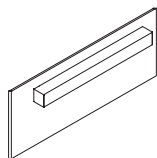
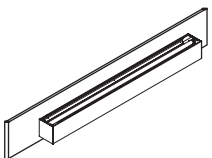

EDGE Evolution Outline

INSTALLATION
INSTRUCTIONS

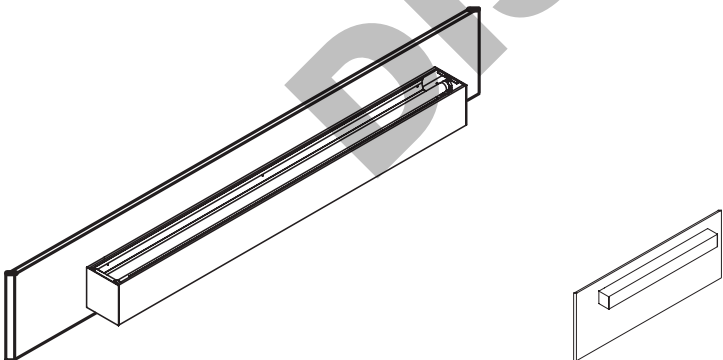

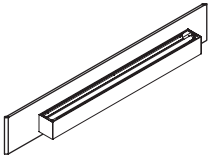

EDGE
EVOLUTION

OUTLINE Installation Instructions

MUST BE INSTALLED PRIOR TO CEILING INSTALLATION.

Setup and Considerations

1. Fixture is to be installed flush with wall.
2. Fixture mounts directly to J-Bar. (See Illustration A)
3. If fixture is not full length of wall, fixture should be centered on wall and End Fillers should be used to make up the difference in length. (see End Filler installation sheet for details.)
4. J-Bar may need to be shimmed prior to fixture installation to accommodate wall inconsistencies. (See Illustration B)

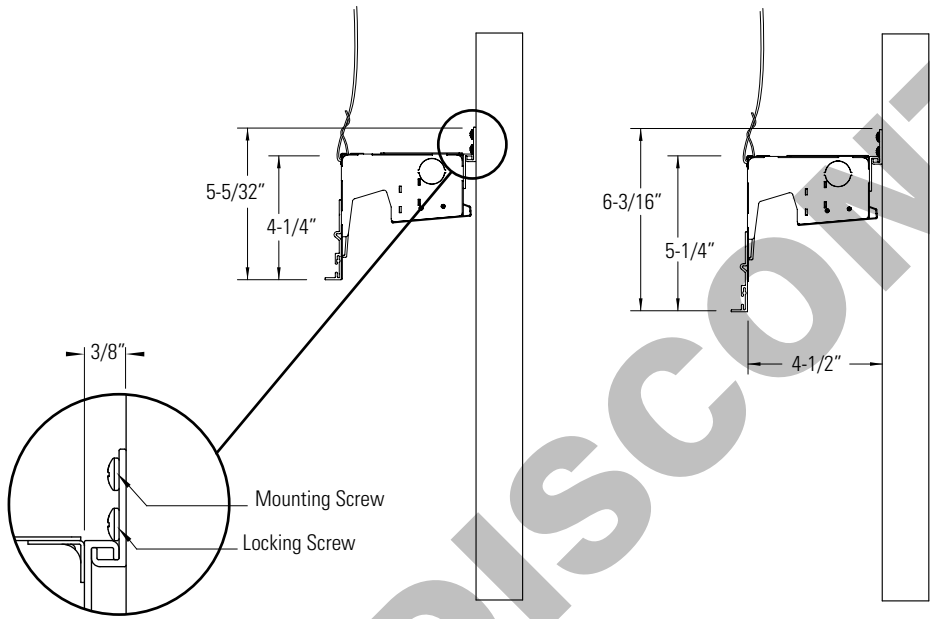
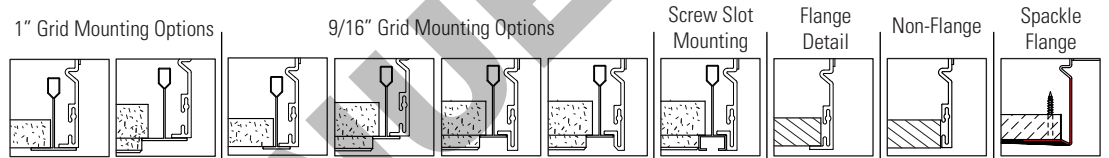
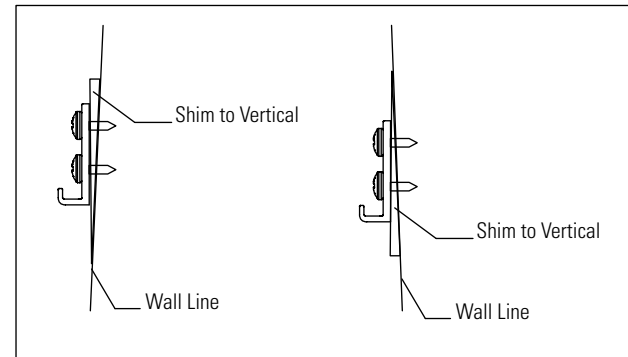

Illustration A

Shim Detail Illustration B



Designed and Fabricated in Denver Colorado

Phone: 303.322.5570

www.pinnacle-ltg.com

October 2014

1. This product must be installed in accordance with applicable installation and electrical codes by a professional familiar with the construction and operation of the product.
2. Minimum 90°C supply conductors
3. All electrical connections must be performed by a certified electrician to applicable local and national electrical codes.

4. Fixtures must be mounted directly to structure.
5. The holding strength of AC cables cannot be guaranteed if the cables are damaged in any way.
6. All of Pinnacle's packaging is recyclable with the exception of the straps on the pallets. Please reach out to the factory if you need assistance in recycling any packaging components.

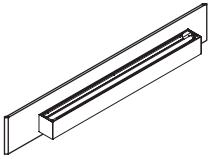

EDGE
EVOLUTION

OUTLINE Installation Instructions

MUST BE INSTALLED PRIOR TO CEILING INSTALLATION.

Step 1: Wall Bracket (J Bar)

1. Attach J Bar to wall at desired mount height.
2. Use only top holes (2) for mounting J Bar to wall.

(Note: Each J Bar has 5 screw holes. 2 upper holes for mounting J Bar and 3 lower holes for "locking" fixture to J Bar.)

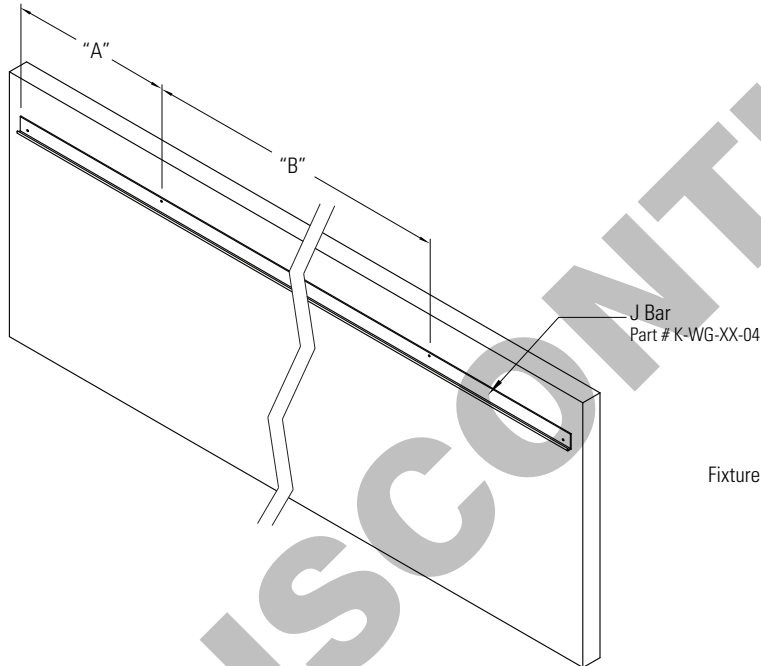

Dim "A"	Dim "B"
12-5/16"	23-3/8"

Dim "A" is from end of J Bar to first mounting hole
Dim "B" is from mounting hole to mounting hole

Step 2: Installing and Wiring

1. Fixture mounts on J Bar and against wall. **See illustration B**
2. Once installed and resting in J Bar put screw into lower screw holes (3) in J Bar to "lock" fixture in. **See illustration A on pg. 1**
3. Secure and level fixture to building structure with tie offs on non wall side of housing.
4. Run building power to fixture, make necessary wire connections via access plate on top of fixture.

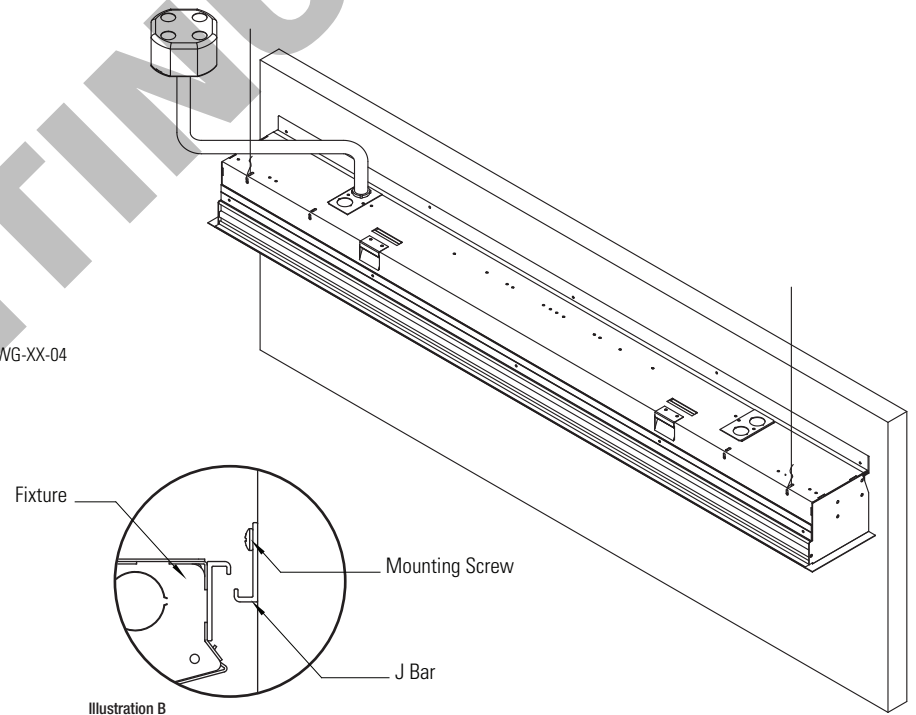

1. This product must be installed in accordance with applicable installation and electrical codes by a professional familiar with the construction and operation of the product.
2. Minimum 90°C supply conductors
3. All electrical connections must be performed by a certified electrician to applicable local and national electrical codes.

4. Fixtures must be mounted directly to structure.
5. The holding strength of AC cables cannot be guaranteed if the cables are damaged in any way.
6. All of Pinnacle's packaging is recyclable with the exception of the straps on the pallets. Please reach out to the factory if you need assistance in recycling any packaging components.



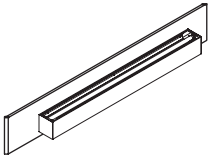

EDGE
EVOLUTION

OUTLINE Installation Instructions

MUST BE INSTALLED PRIOR TO CEILING INSTALLATION.

Step 3: Opening the Driver Cover

1. Open the driver cover by removing the screws in the cover, one screw per end.
2. Once the screws are removed the driver cover swings open and remains captive to the fixture.

Step 4: Joining Fixtures

1. With the driver covers open, align fixtures with joining biscuits and butt fixtures together.
2. Secure fixtures using provided screws through brackets fixture joints.

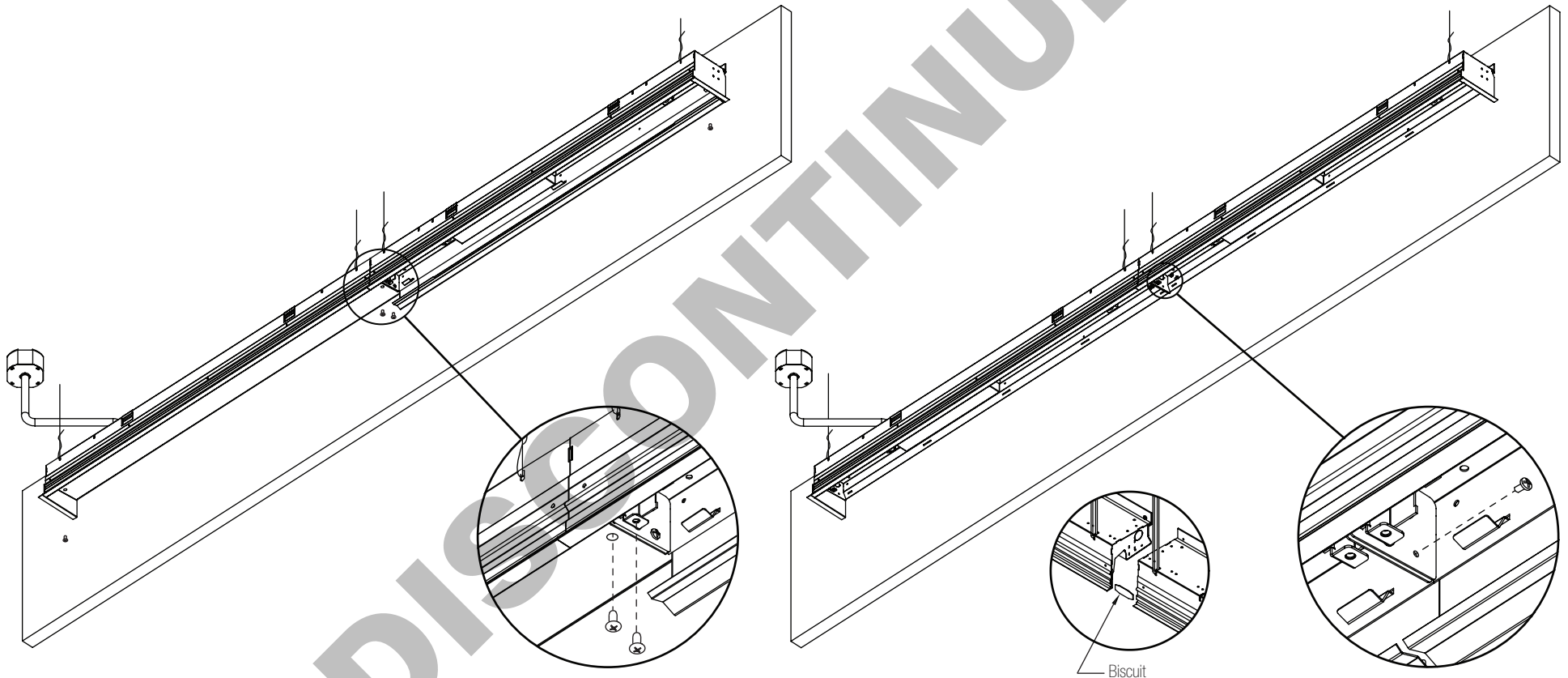

1. This product must be installed in accordance with applicable installation and electrical codes by a professional familiar with the construction and operation of the product.
2. Minimum 90°C supply conductors
3. All electrical connections must be performed by a certified electrician to applicable local and national electrical codes.

4. Fixtures must be mounted directly to structure.
5. The holding strength of AC cables cannot be guaranteed if the cables are damaged in any way.
6. All of Pinnacle's packaging is recyclable with the exception of the straps on the pallets. Please reach out to the factory if you need assistance in recycling any packaging components.

EDGE Evolution Outline

END FILLER
INSTALLATION

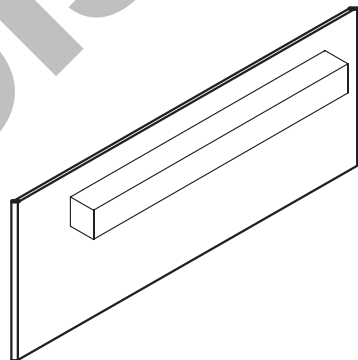
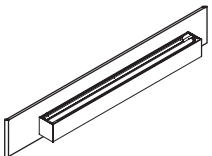

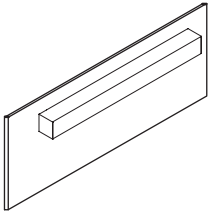

MUST BE INSTALLED PRIOR TO CEILING INSTALLATION.

Unit Breakdown

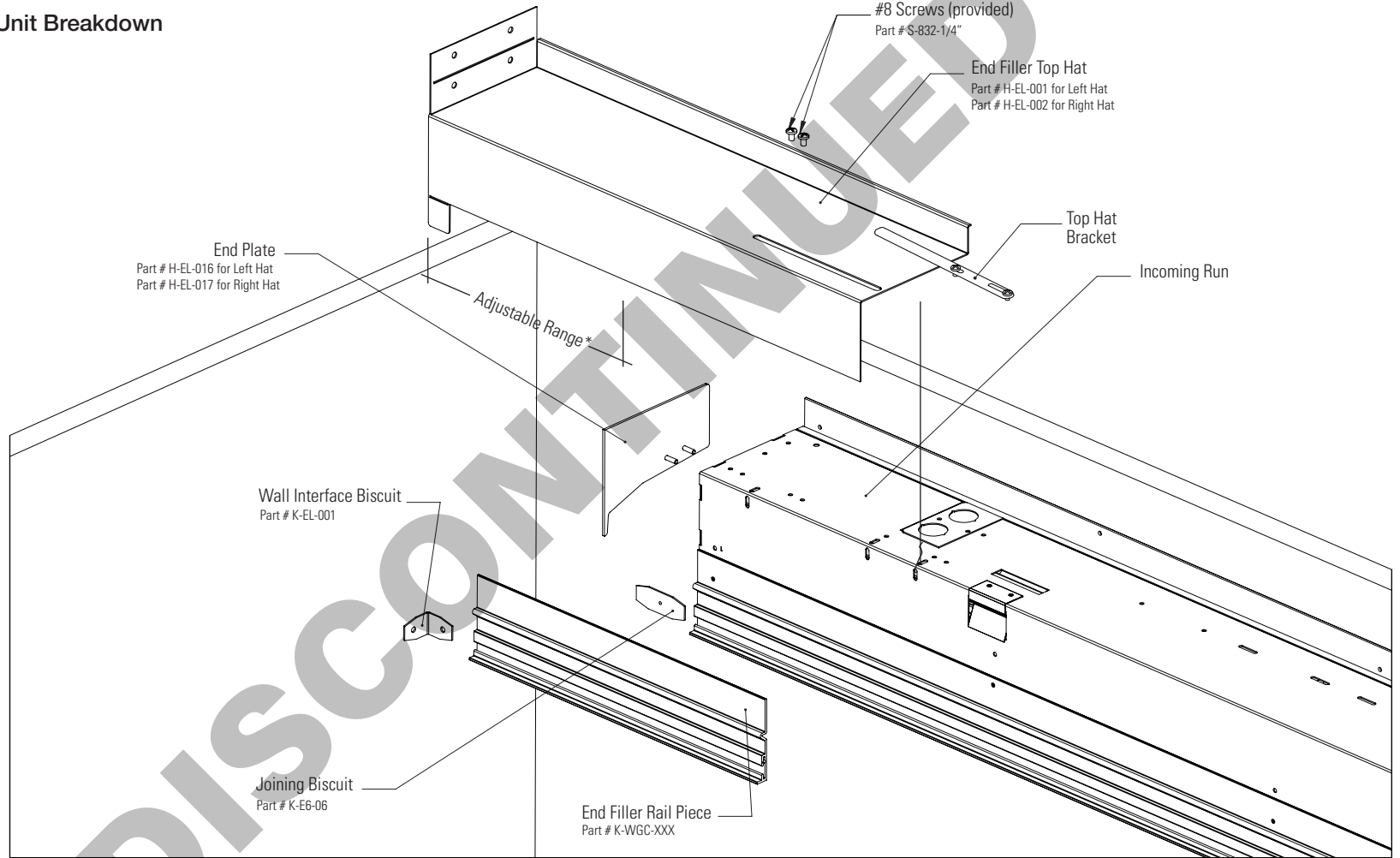

***Adjustable 1" to 12", recommended max 6"**

For incoming row see EVL_WS installation instructions



1. This product must be installed in accordance with applicable installation and electrical codes by a professional familiar with the construction and operation of the product.
2. Minimum 90°C supply conductors
3. All electrical connections must be performed by a certified electrician to applicable local and national electrical codes.

4. Fixtures must be mounted directly to structure.
5. The holding strength of AC cables cannot be guaranteed if the cables are damaged in any way.
6. All of Pinnacle's packaging is recyclable with the exception of the straps on the pallets. Please reach out to the factory if you need assistance in recycling any packaging components.

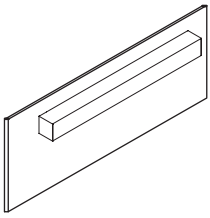

EDGE
EVOLUTION

OUTLINE

End Filler Installation Instructions

MUST BE INSTALLED PRIOR TO CEILING INSTALLATION.

Step 1: End Plate

1. Attach end plate through holes in end of approaching fixture and nut (provided) from inside the fixture.
2. Make sure J rail is cut back to the end of the fixture.

Step 2: Filler Rail

1. Measure the distance from the end of the fixture to the wall.
2. Cut the End Filler Rail Piece to the above measured dimension.
3. Insert both Wall Interface Biscuit and Joining Biscuit into End Filler Piece.
4. Level End Filler Rail and slide Joining Biscuit to join the End Filler Rail to the Fixture Rail.
5. Secure the Wall Interface Biscuit to the wall with screw (by others).

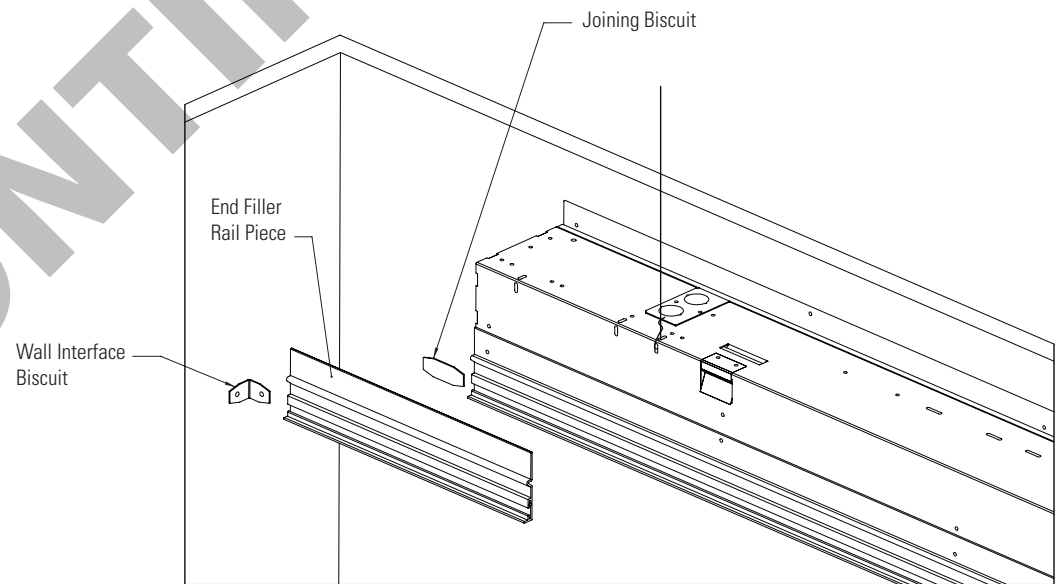
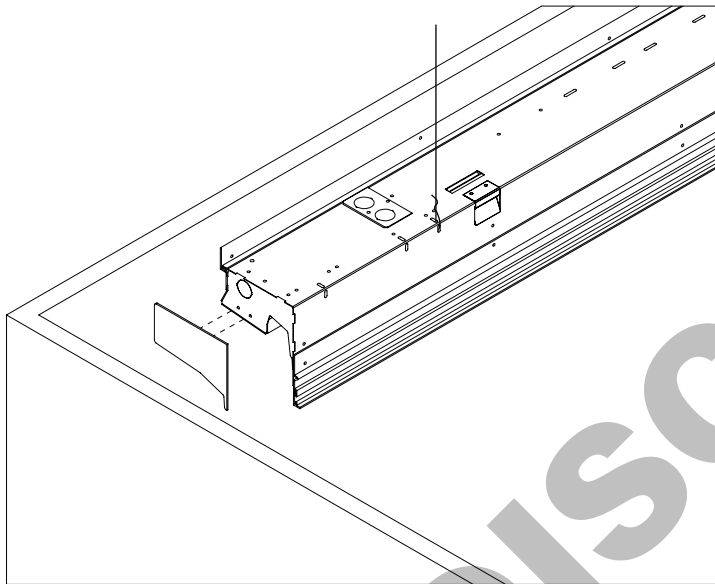

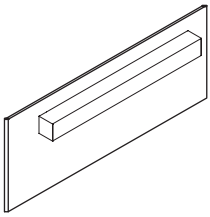

EDGE
EVOLUTION

OUTLINE

End Filler Installation Instructions

MUST BE INSTALLED PRIOR TO CEILING INSTALLATION.

Step 3: Top Hat

1. If electrical access is needed, trim End Filler Top Hat to needed length.
2. Place Top Hat on top of fixture and butt up to wall.
3. Attach top hat through slot using #8 screws provided. If Top Hat was trimmed, utilize Top Hat Bracket to attach Top Hat to incoming fixture
4. Screw Top Hat to wall (screws by others).

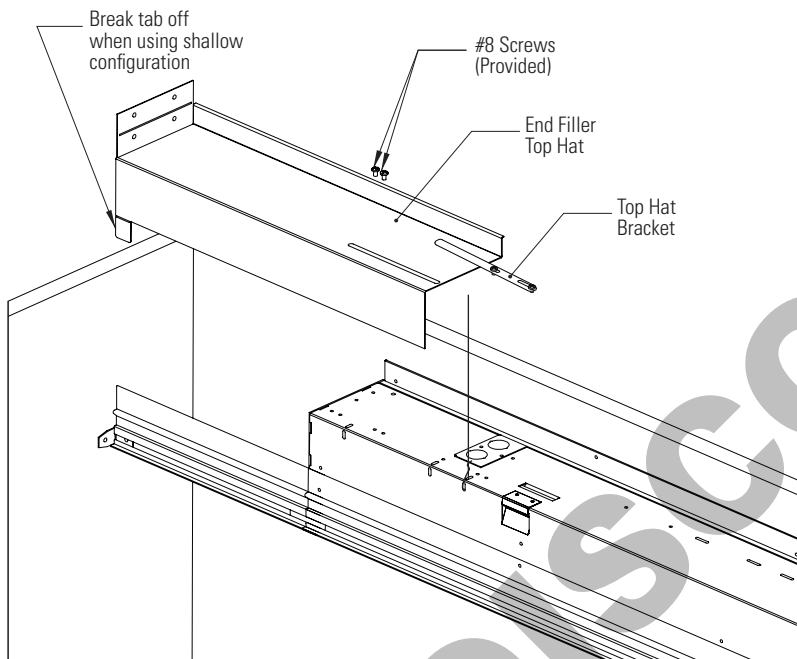

Optional: End Trim

1. Optional End Trim used with grid, flanged, or spackle flange mounting options.
2. Secure end trim using 3 screws (provided)

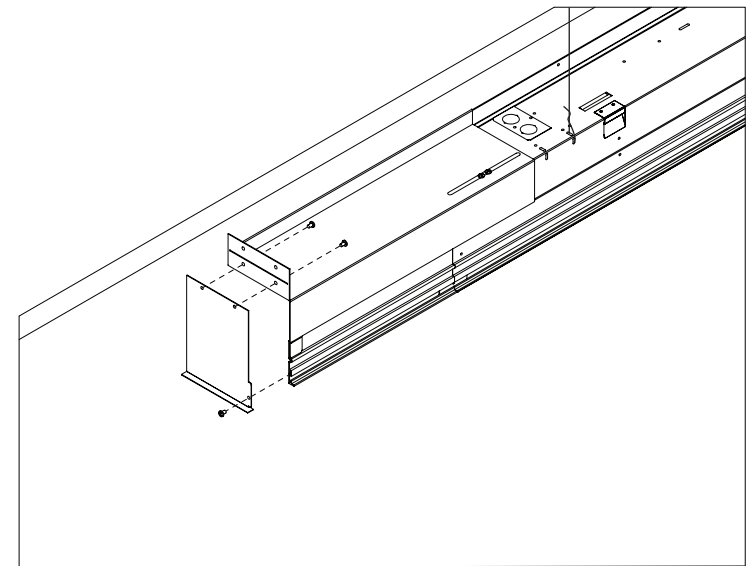

Designed and Fabricated in Denver Colorado

Phone: 303.322.5570

www.pinnacle-ltg.com

November 2014

1. This product must be installed in accordance with applicable installation and electrical codes by a professional familiar with the construction and operation of the product.
2. Minimum 90°C supply conductors
3. All electrical connections must be performed by a certified electrician to applicable local and national electrical codes.

4. Fixtures must be mounted directly to structure.
5. The holding strength of AC cables cannot be guaranteed if the cables are damaged in any way.
6. All of Pinnacle's packaging is recyclable with the exception of the straps on the pallets. Please reach out to the factory if you need assistance in recycling any packaging components.

EDGE Evolution Outline

OUTSIDE CORNER
INSTALLATION

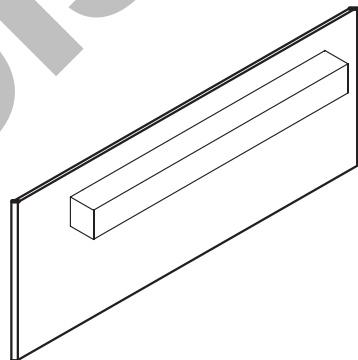
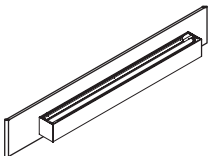

DISCONTINUED

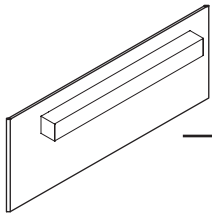

EDGE
EVOLUTION

OUTLINE Outside Corner Installation Instructions

MUST BE INSTALLED PRIOR TO CEILING INSTALLATION.

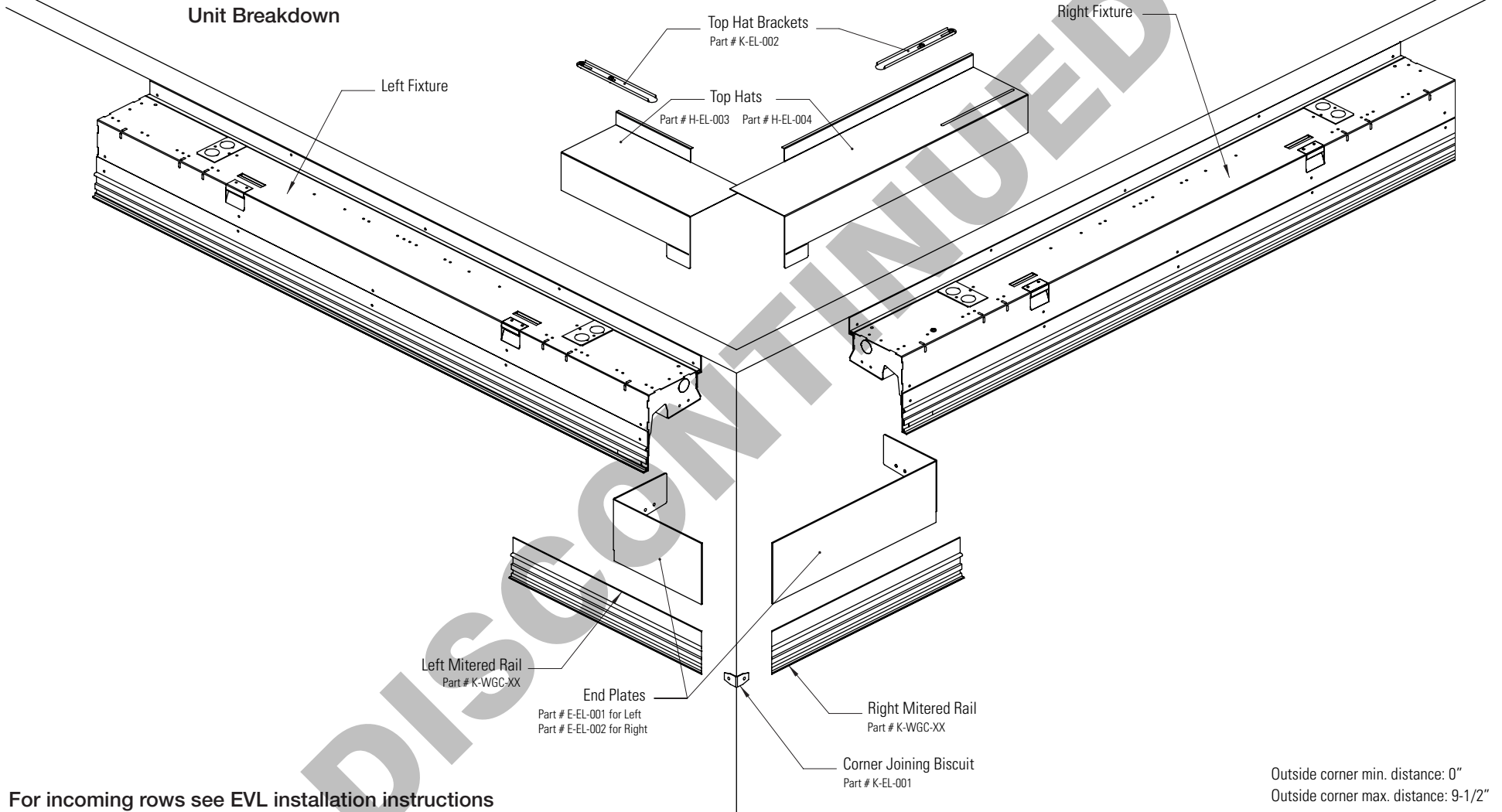

For incoming rows see EVL installation instructions

Outside corner min. distance: 0"
Outside corner max. distance: 9-1/2"



1. This product must be installed in accordance with applicable installation and electrical codes by a professional familiar with the construction and operation of the product.
2. Minimum 90°C supply conductors
3. All electrical connections must be performed by a certified electrician to applicable local and national electrical codes.

4. Fixtures must be mounted directly to structure.
5. The holding strength of AC cables cannot be guaranteed if the cables are damaged in any way.
6. All of Pinnacle's packaging is recyclable with the exception of the straps on the pallets. Please reach out to the factory if you need assistance in recycling any packaging components.

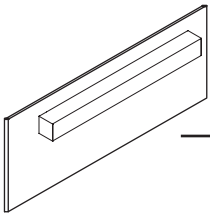

EDGE
EVOLUTION

OUTLINE

Outside Corner Installation Instructions

MUST BE INSTALLED PRIOR TO CEILING INSTALLATION.

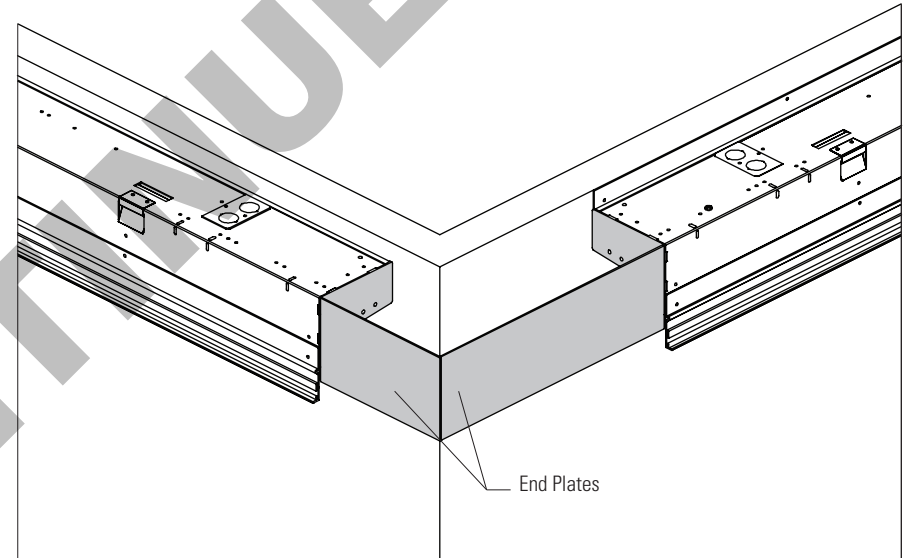
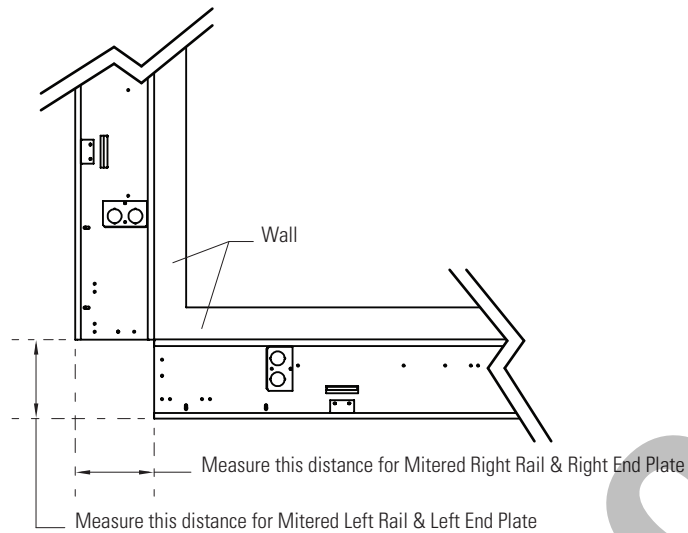

Step 1:

Prepping The Flange Pieces

1. Measure the above noted distances to determine the length of each flange piece.
2. Cut the Mitered Rails and the End Plates to fit the measurements.

Step 2:

End Plates

1. Install End Plates using supplied nuts inside of fixture. 2 nuts per End Plate.



1. This product must be installed in accordance with applicable installation and electrical codes by a professional familiar with the construction and operation of the product.
2. Minimum 90°C supply conductors
3. All electrical connections must be performed by a certified electrician to applicable local and national electrical codes.

4. Fixtures must be mounted directly to structure.
5. The holding strength of AC cables cannot be guaranteed if the cables are damaged in any way.
6. All of Pinnacle's packaging is recyclable with the exception of the straps on the pallets. Please reach out to the factory if you need assistance in recycling any packaging components.

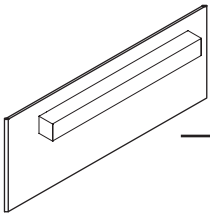

EDGE
EVOLUTION

OUTLINE Outside Corner Installation Instructions

MUST BE INSTALLED PRIOR TO CEILING INSTALLATION.

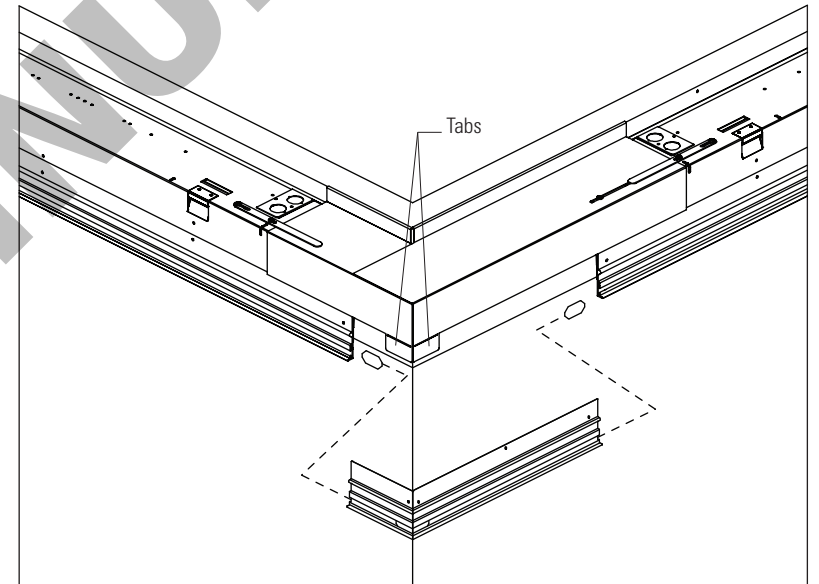
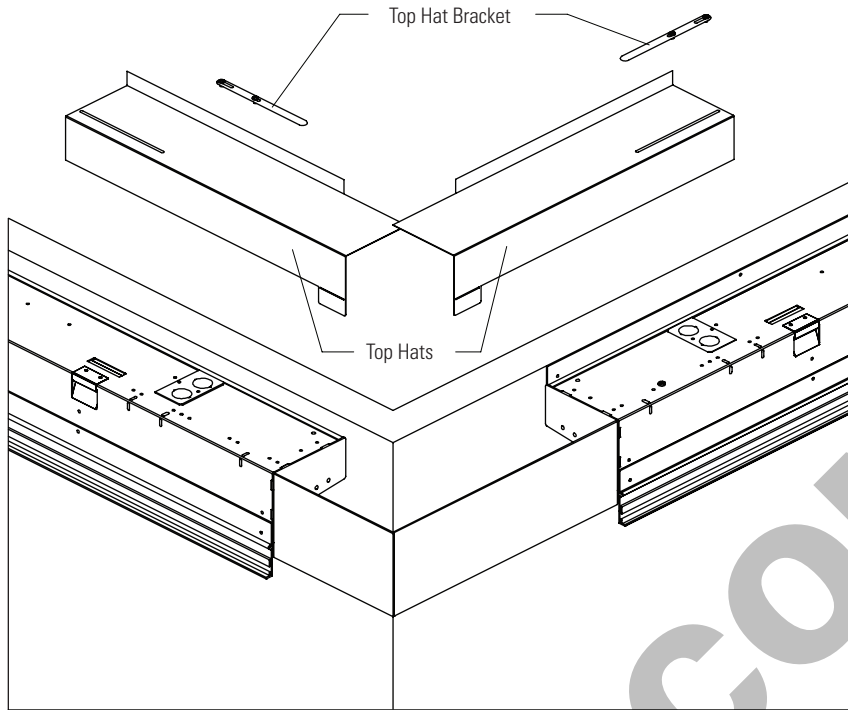

Step 3: Top Hats and Top Hat Brackets

1. Secure top hat(s) to housing through slot using provided #8 screws
2. If screw location is not available trim Top Hat to reveal holes. And use Top Hat Bracket to attach Top Hat to fixture.

Step 4: Corner Flange Pieces

1. Using the Rail pieces cut in Step 1 and the corner joining biscuit, you will have the corner Rail piece.
2. Attach the corner Rail piece with the supplied joining biscuits.
3. If using the EVL fixture (5-1/4" tall) add double sided tape to the tabs on the top hats. If using EVLS fixture (4-1/4" tall) remove the tabs.



1. This product must be installed in accordance with applicable installation and electrical codes by a professional familiar with the construction and operation of the product.
2. Minimum 90°C supply conductors
3. All electrical connections must be performed by a certified electrician to applicable local and national electrical codes.

4. Fixtures must be mounted directly to structure.
5. The holding strength of AC cables cannot be guaranteed if the cables are damaged in any way.
6. All of Pinnacle's packaging is recyclable with the exception of the straps on the pallets. Please reach out to the factory if you need assistance in recycling any packaging components.

EDGE Evolution Outline

ILLUMINATED INSIDE
CORNER INSTALLATION

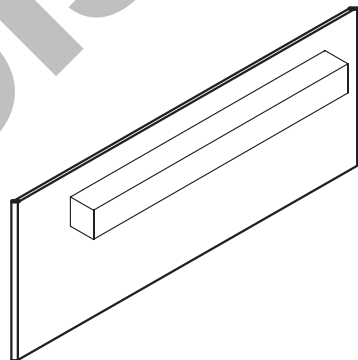
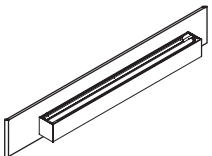

DISCONTINUED

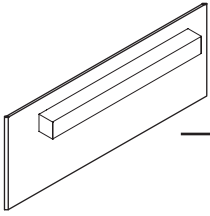

EDGE
EVOLUTION

OUTLINE Inside Corner Installation Instructions

MUST BE INSTALLED PRIOR TO CEILING INSTALLATION.

Unit Breakdown

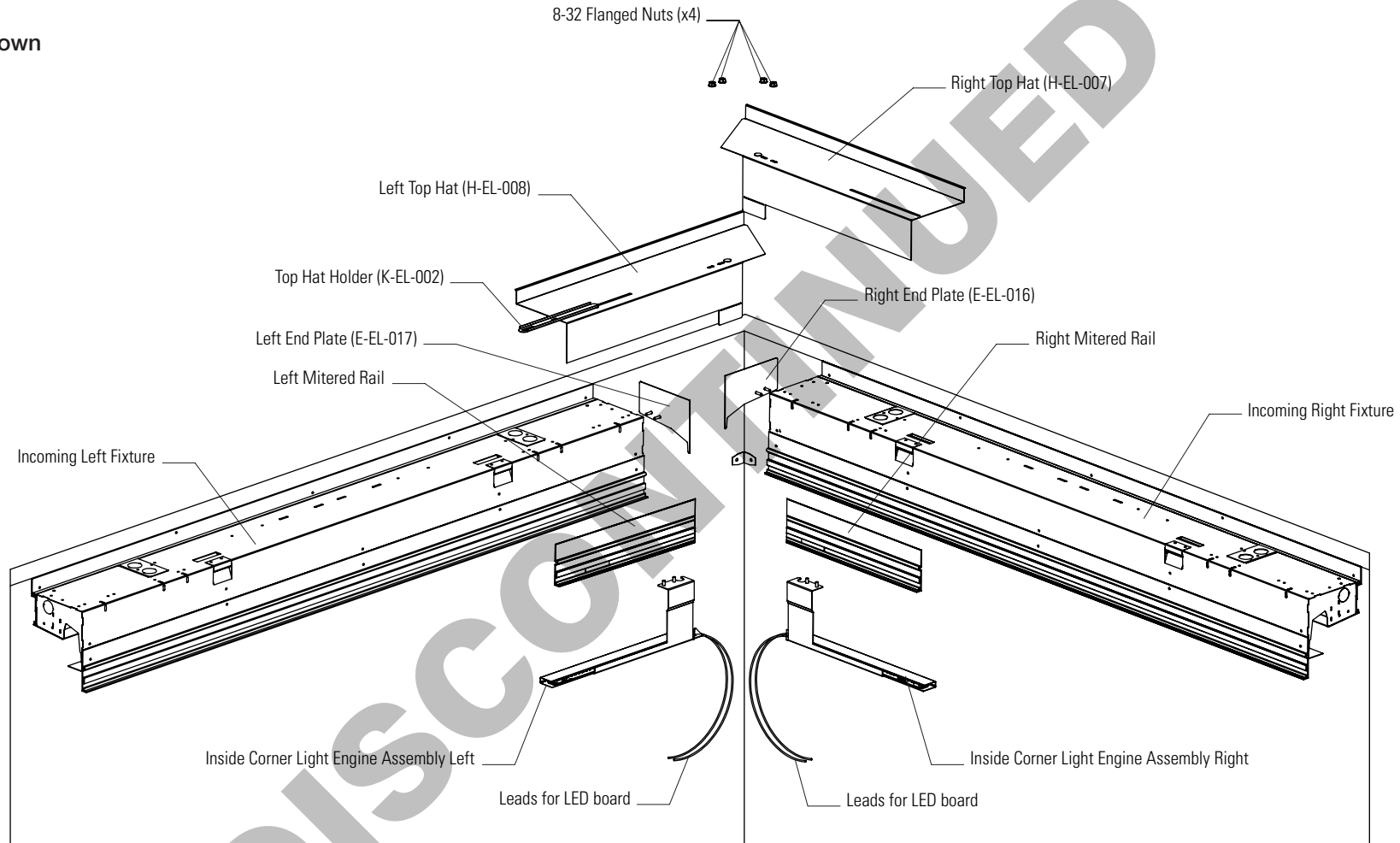

For incoming rows see EVL installation instructions

Note: Incoming fixtures are specific to corner and contain an extra driver. See submittal for more information.



1. This product must be installed in accordance with applicable installation and electrical codes by a professional familiar with the construction and operation of the product.
2. Minimum 90°C supply conductors
3. All electrical connections must be performed by a certified electrician to applicable local and national electrical codes.

4. Fixtures must be mounted directly to structure.
5. The holding strength of AC cables cannot be guaranteed if the cables are damaged in any way.
6. All of Pinnacle's packaging is recyclable with the exception of the straps on the pallets. Please reach out to the factory if you need assistance in recycling any packaging components.

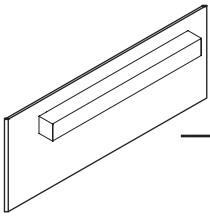

EDGE
EVOLUTION

OUTLINE Inside Corner Installation Instructions

MUST BE INSTALLED PRIOR TO CEILING INSTALLATION.

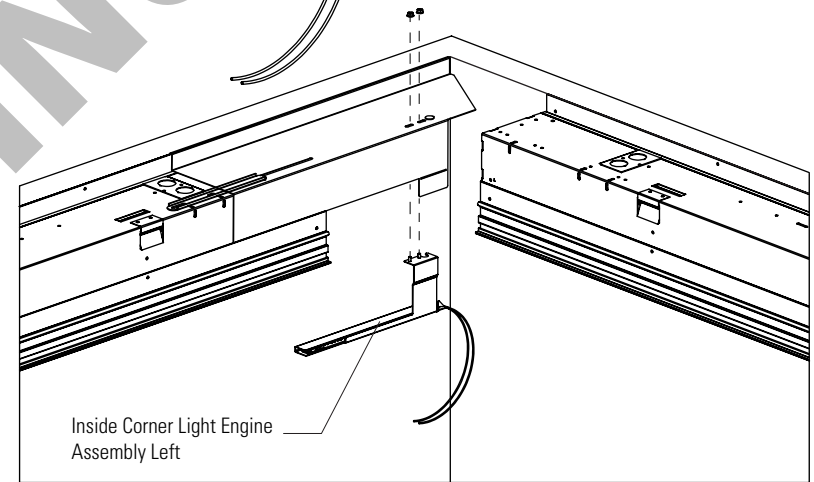
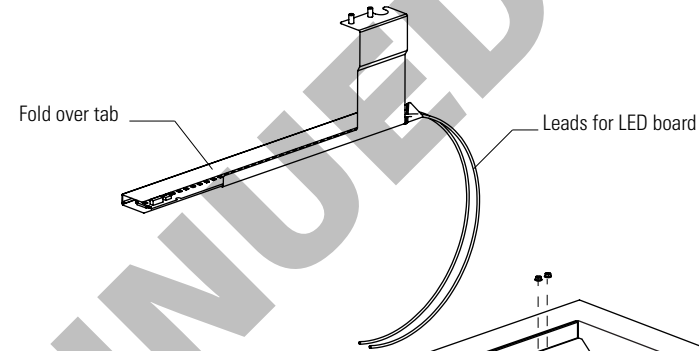
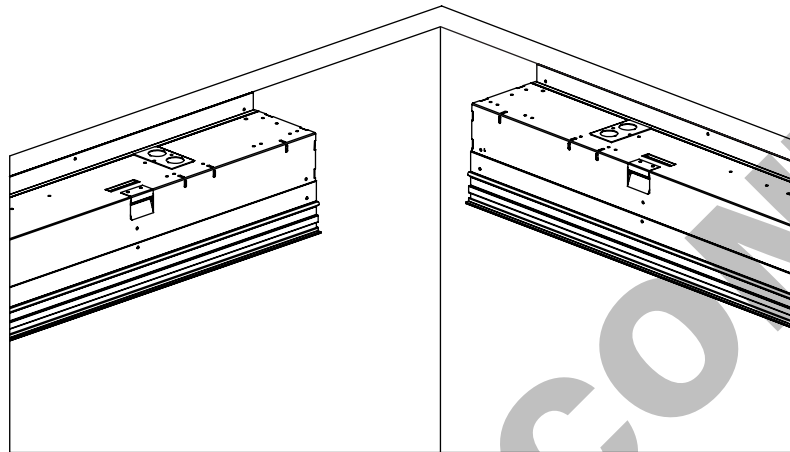
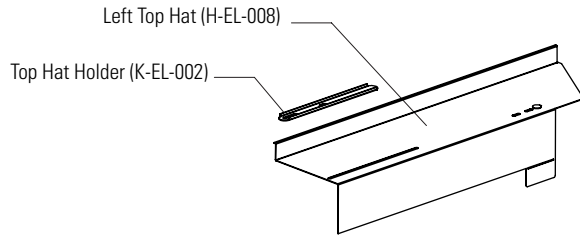

Step 1: Left Top Hat

1. Install the Left Top Hat over the top of the left side of incoming fixture. (Note: The Top Hat might need to be cut to allow access to electrical cover.)
2. If Top Hat is cut, install using Top Hat Holder.
3. Top Hat or Top Hat Holder installs with two (2) #8 Screws (provided)

Step 2: Getting Light in Your Corner

1. Before installing the Corner Light Engine Assembly, measure back to the beginning of the incoming fixture. Use this measurement, trim fold over tab to expose LED diodes up into the corner.
2. Installing the Corner Light Engine Assembly is done by attaching the assembly to the inside of the Top Hat using two (2) #8 Flanged Nuts (provided)



1. This product must be installed in accordance with applicable installation and electrical codes by a professional familiar with the construction and operation of the product.
2. Minimum 90°C supply conductors
3. All electrical connections must be performed by a certified electrician to applicable local and national electrical codes.

4. Fixtures must be mounted directly to structure.
5. The holding strength of AC cables cannot be guaranteed if the cables are damaged in any way.
6. All of Pinnacle's packaging is recyclable with the exception of the straps on the pallets. Please reach out to the factory if you need assistance in recycling any packaging components.

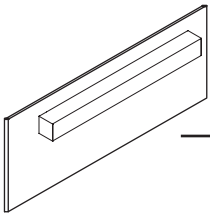

EDGE
EVOLUTION

OUTLINE Inside Corner Installation Instructions

MUST BE INSTALLED PRIOR TO CEILING INSTALLATION.

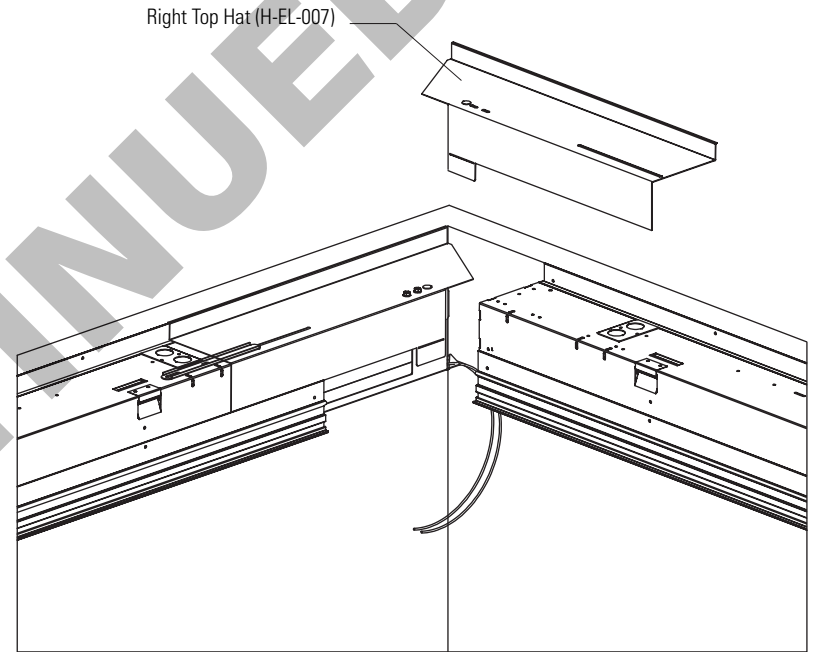
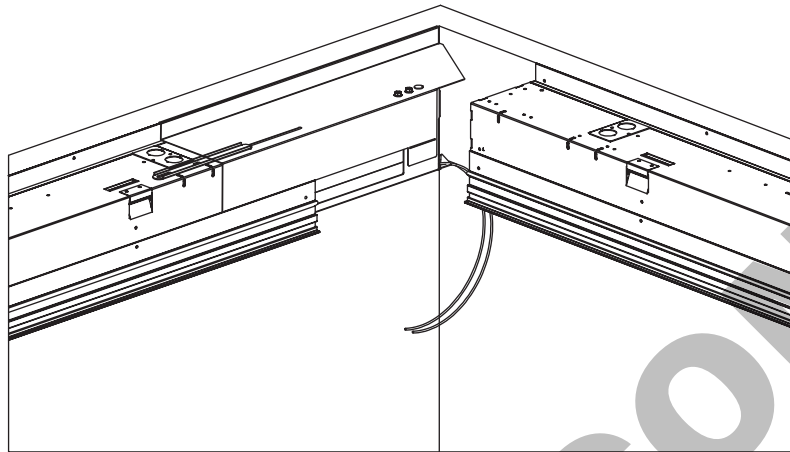
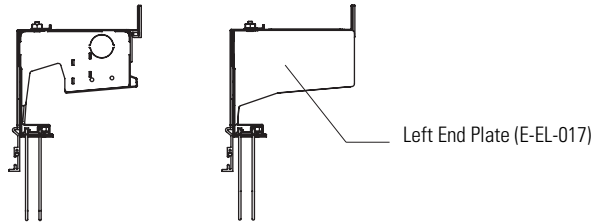

Step 3: End Trim

1. Once the Top Hat and the Light Engine Assembly is installed you can install the End Plate.
2. From inside the corner slide End Plate into place. Pins will go through two (2) holes in end of fixture.

Step 4: Right Top Hat

1. Install the Right Top Hat over the top of the right side of incoming fixture. (Note: The Top Hat might need to be cut to allow access to electrical cover.)
2. If Top Hat is cut install using Top Hat Holder.
3. Top Hat or Top Hat Holder installs with two (2) #8 Screws (provided)



1. This product must be installed in accordance with applicable installation and electrical codes by a professional familiar with the construction and operation of the product.
2. Minimum 90°C supply conductors
3. All electrical connections must be performed by a certified electrician to applicable local and national electrical codes.

4. Fixtures must be mounted directly to structure.
5. The holding strength of AC cables cannot be guaranteed if the cables are damaged in any way.
6. All of Pinnacle's packaging is recyclable with the exception of the straps on the pallets. Please reach out to the factory if you need assistance in recycling any packaging components.

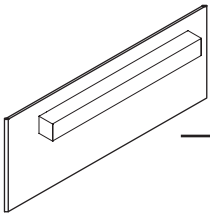

EDGE
EVOLUTION

OUTLINE Inside Corner Installation Instructions

MUST BE INSTALLED PRIOR TO CEILING INSTALLATION.

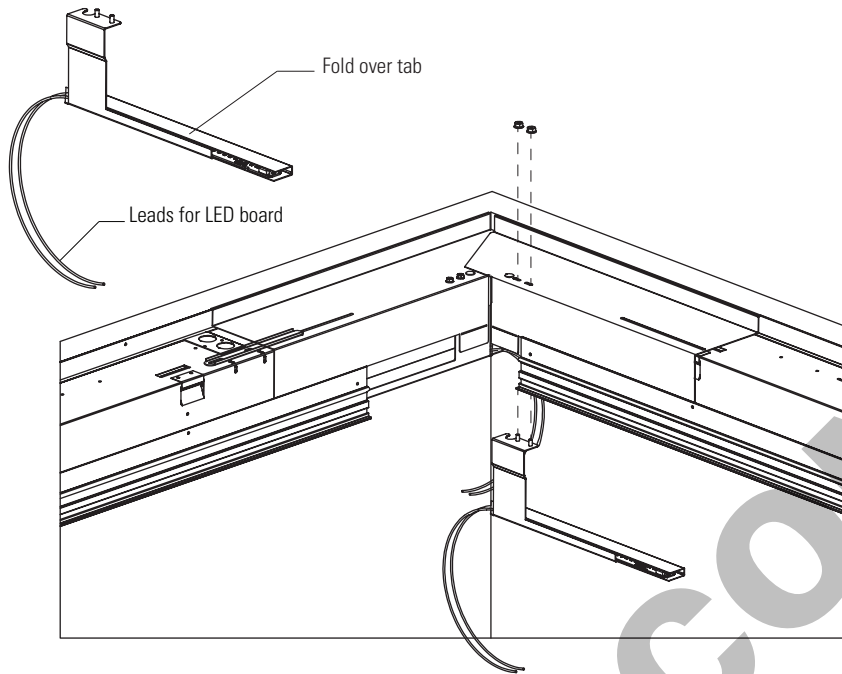

Step 5: Getting Light in Your Corner

1. Before installing the Corner Light Engine Assembly, measure back to the beginning of the incoming fixture. Use this measurement, trim fold over tab to expose LED diodes up into the corner.
2. Installing the Corner Light Engine Assembly is done by attaching the assembly to the inside of the Top Hat using two (2) #8 Flanged Nuts (provided)

Step 6: End Trim

1. Once the Top Hat and the Light Engine Assembly are installed, you can install the End Plate.
2. From inside the corner, slide End Plate into place, pems will go through two (2) holes in end of fixture.



1. This product must be installed in accordance with applicable installation and electrical codes by a professional familiar with the construction and operation of the product.
2. Minimum 90°C supply conductors
3. All electrical connections must be performed by a certified electrician to applicable local and national electrical codes.

4. Fixtures must be mounted directly to structure.
5. The holding strength of AC cables cannot be guaranteed if the cables are damaged in any way.
6. All of Pinnacle's packaging is recyclable with the exception of the straps on the pallets. Please reach out to the factory if you need assistance in recycling any packaging components.

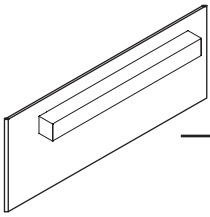

EDGE
EVOLUTION

OUTLINE

Inside Corner Installation Instructions

MUST BE INSTALLED PRIOR TO CEILING INSTALLATION.

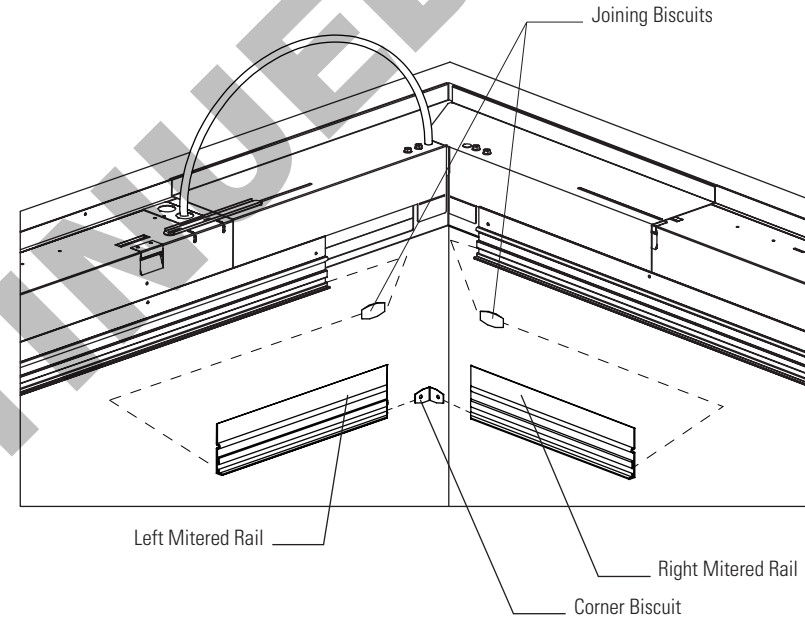
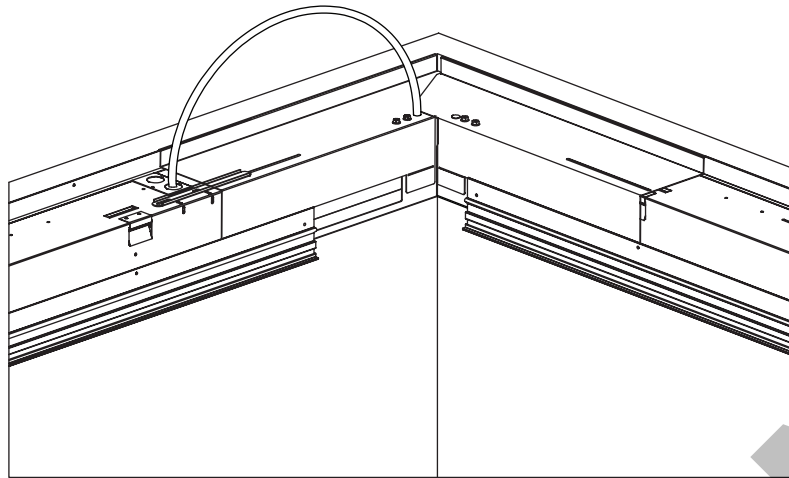

Step 7:

Powering the Corner

1. Cover the low voltage leads coming from the Light Engine Assemblies using the provided white shielding.
2. Run the shielded leads through the top of the Top Hat and back to the corresponding fixture as called out in the submittal.
3. Make electrical connections inside fixture using provided quick disconnect.

Step 8:

Corner Flange Pieces

1. Measure and cut provided Mitered Rails to fit into corner.
2. Attach rails together using provided Corner Joining Biscuit.
3. Slide Joining Biscuits (one each) into the outside ends of each side of corner rails.
4. Insert corner rails into corner and slide Joining Biscuits into place between corner rails and fixture rails.



1. This product must be installed in accordance with applicable installation and electrical codes by a professional familiar with the construction and operation of the product.
2. Minimum 90°C supply conductors
3. All electrical connections must be performed by a certified electrician to applicable local and national electrical codes.

4. Fixtures must be mounted directly to structure.
5. The holding strength of AC cables cannot be guaranteed if the cables are damaged in any way.
6. All of Pinnacle's packaging is recyclable with the exception of the straps on the pallets. Please reach out to the factory if you need assistance in recycling any packaging components.