



Grid Installation.....	2
Inside Corner Installation.....	3
Horizontal Corner Installation.....	4
Outside Corner Installation.....	5
Straight Field Cut Illuminated Extension.....	6-10
Angled Field Cut Illuminated Extension.....	11-15
Lens Detail.....	16



**1 GRID PREPARATION AND INSTALLATION**

Prepare grid to the width needed to accommodate the fixture. Place fixture into grid opening and tie off fixture to support.

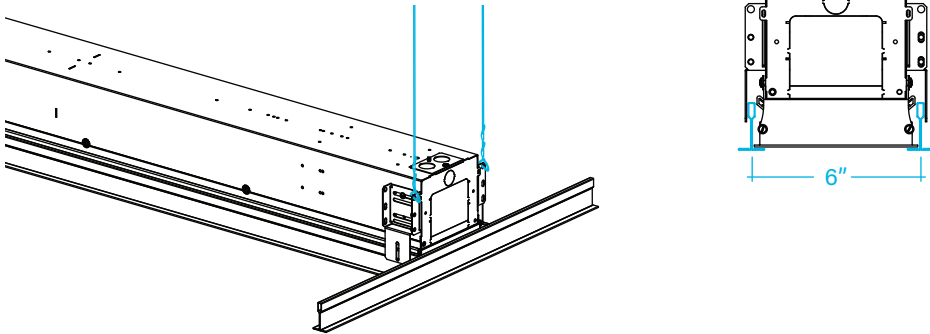

**2 POWER**

Remove Access Plate via one screw. Make wiring connections to building power and replace Access Plate.

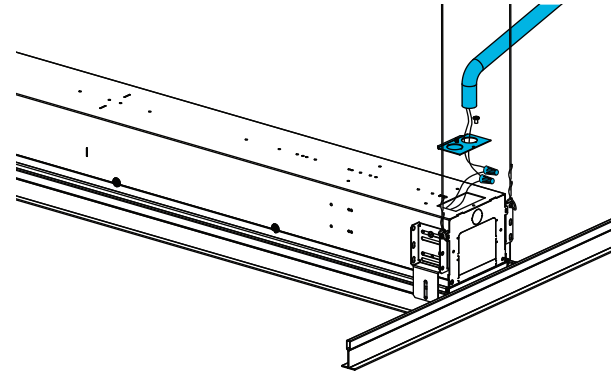

**3 JOINING**

Make wiring connections between fixtures, tap joining biscuit in to one fixture, slide fixtures together, and secure using joining bracket and four screws.

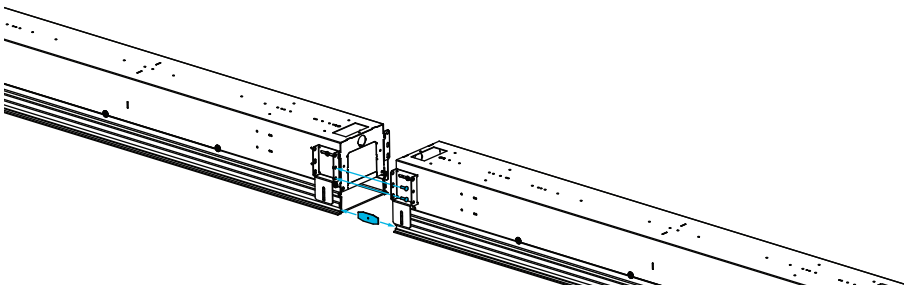

**4 SECURING TO GRID**

Bend grid brackets over and fasten to grid.

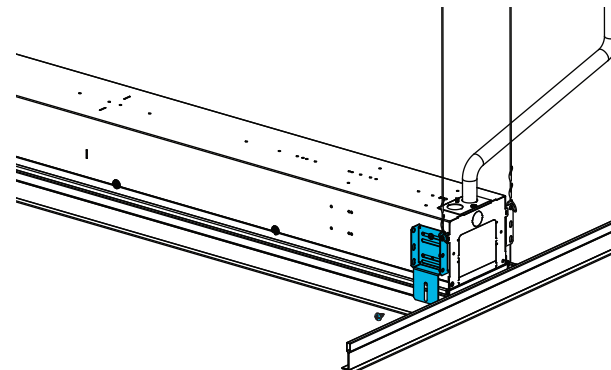



1 CORNER PIECE

Fasten Corner housing to wall fixture. Route wires from wall fixture through corner housing. Install ceiling fixture wiring at corner.

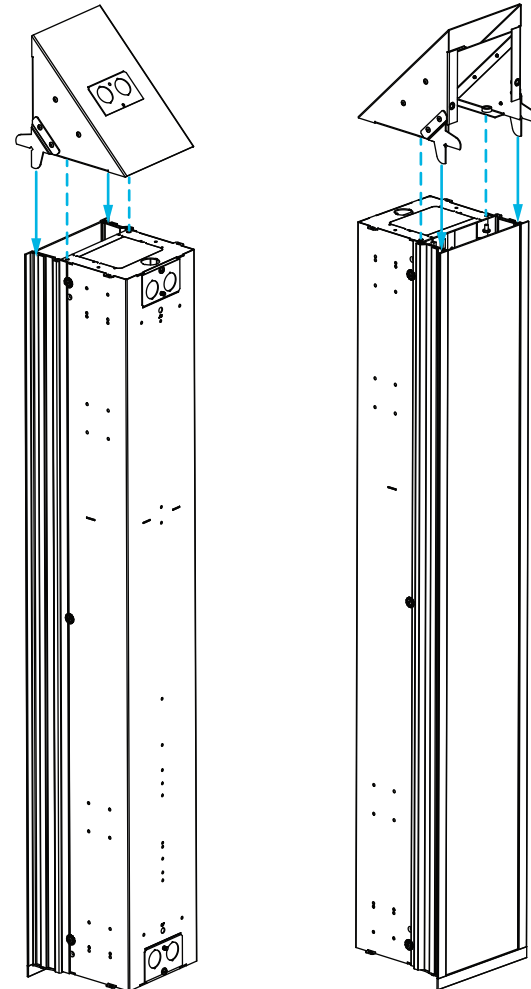
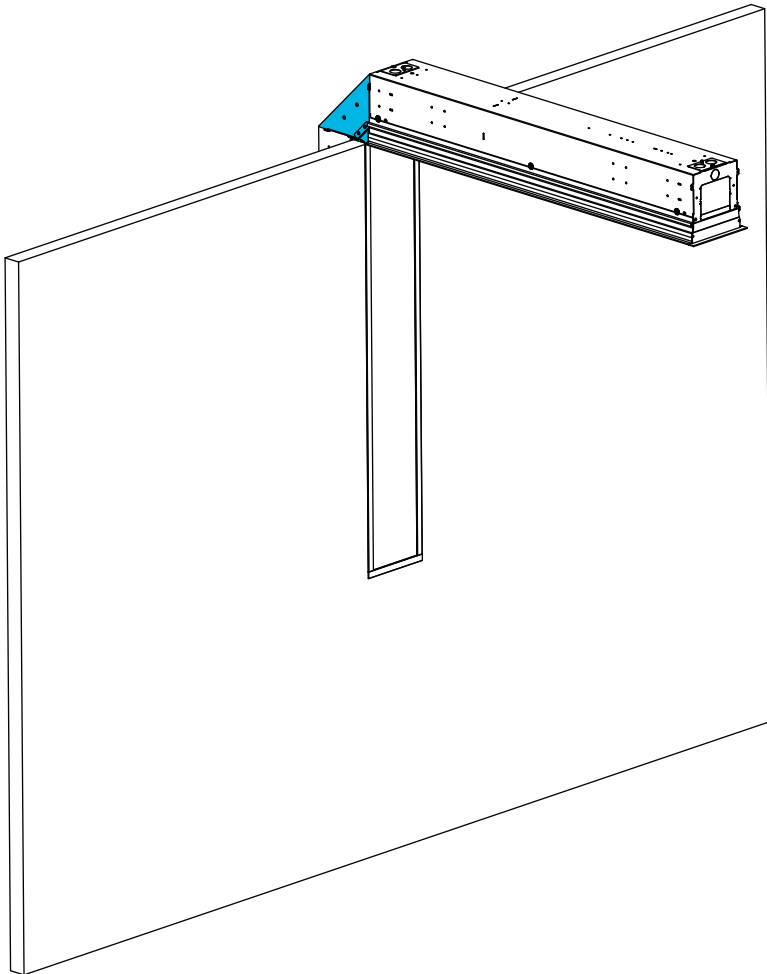



**1 CORNER PIECE**

Lay out fixture and rough-in location. Fixture requires secondary mains, or blocking along the length of fixture, both sides. *(Note: corners are 90°)* Corners install same as fixture(s) and are required to be tied to structure. Remove knock out between fixtures and make necessary wiring connections. Align fixtures using supplied Joining Biscuits (2) and secure fixtures together using Joint Bracket and screws.

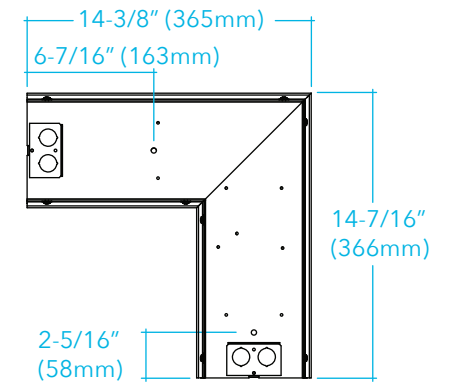
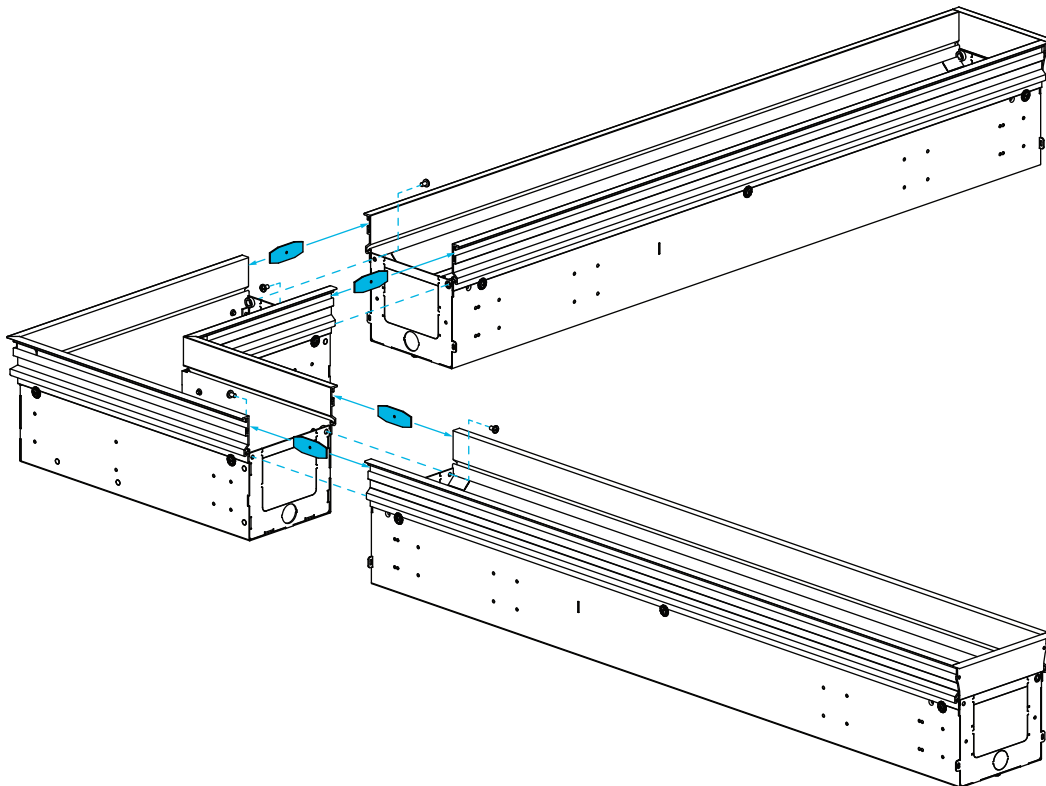



**1 CORNER PIECE**

Lay out fixture and rough-in location. Fixture requires secondary mains, or blocking along the length of fixture, both sides. *(Note: corners are 90°)* Corners install same as fixture(s) and are required to be tied to structure. Remove knock out between fixtures and make necessary wiring connections. Align fixtures using supplied Joining Biscuits (2) and secure fixtures together using Joint Bracket and screws.

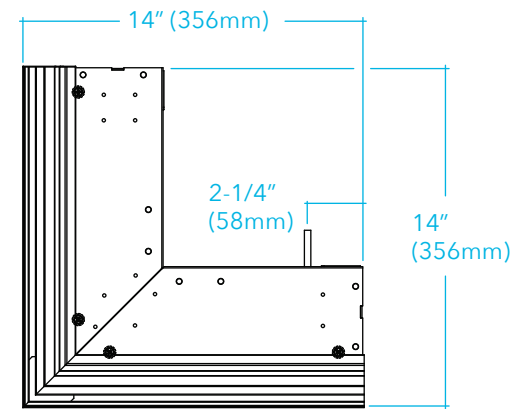
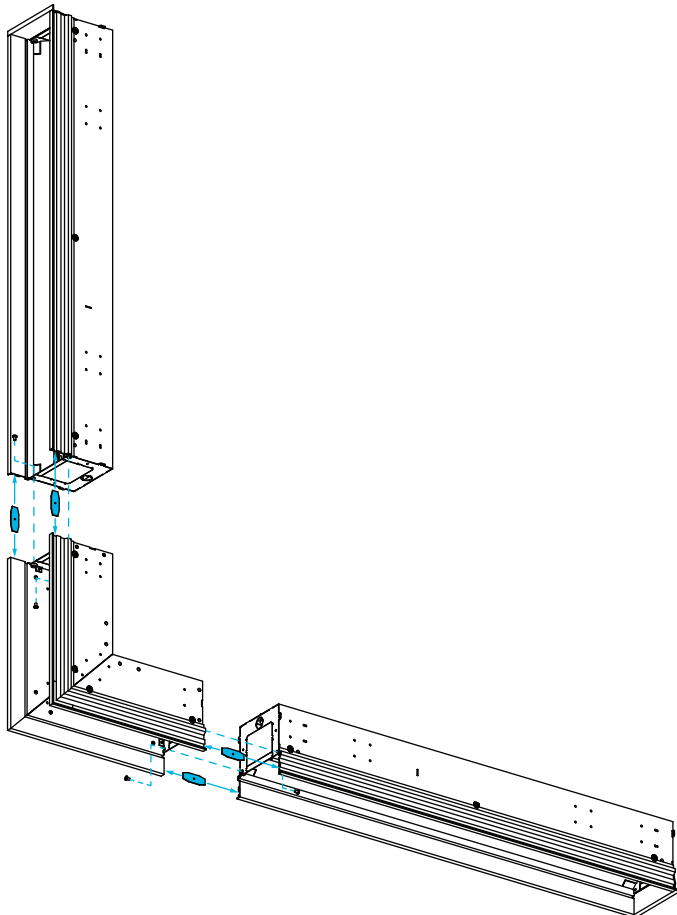



**FIELD CUTTABLE EXTENSION UNIT BREAKDOWN**

Below are the component pieces required for adjusting and installing the extension. Component pieces are located in the fixture box.

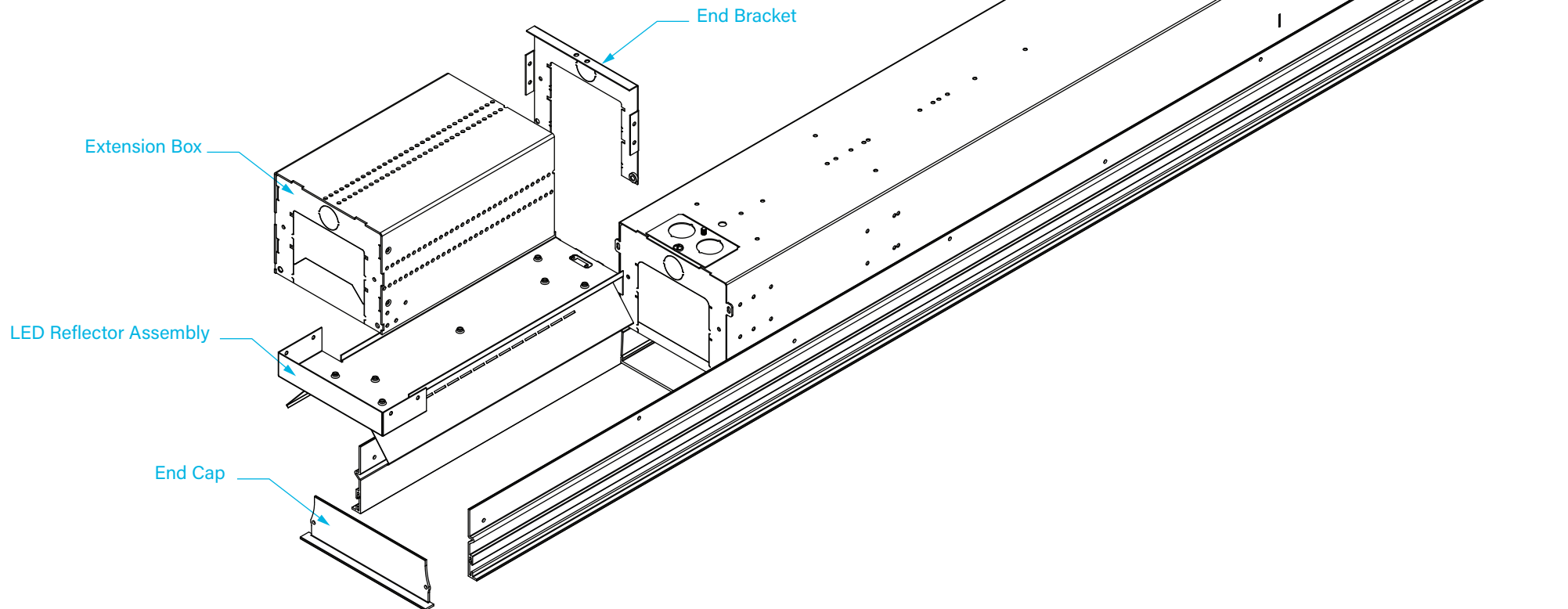



**1 EXTENSION BOX PREP**

Measure the desired length of the final assembled fixture (Extension Box + Main Fixture). Measure the required length from the end of the extension box. Make sure to measure from the end that attached to the main fixture.

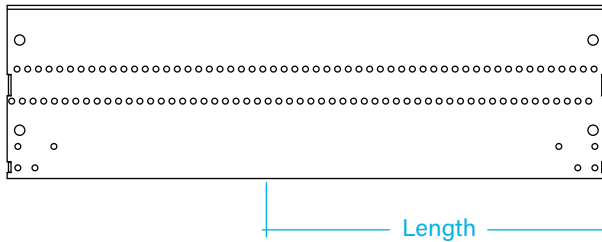
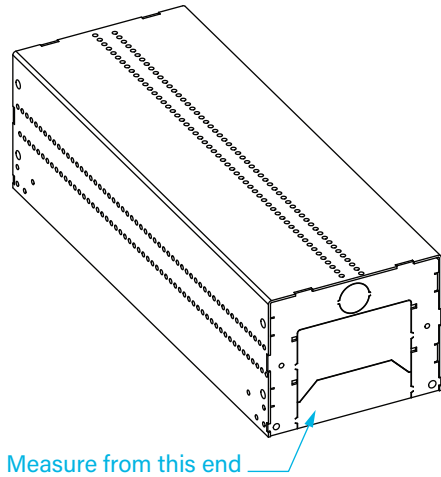

**2 END BRACKET SETUP**

After cutting the extension box, locate end bracket. Attach end bracket to the open end of the extension box via 4 screws on side. This side will be what connects to the main fixture.

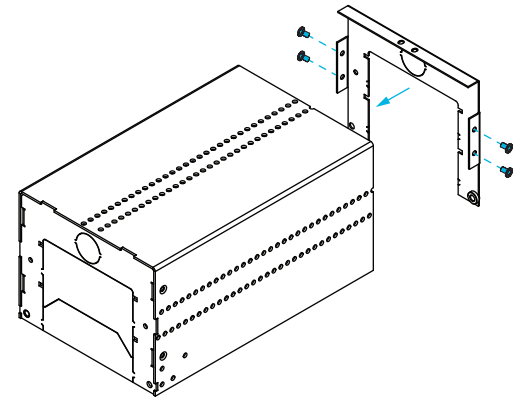



## 1 EXTENSION BOX ASSEMBLY

The LED assembly is made up of 3 parts. The LED board, the reflector, and the bracket. All three are connected using screws. 4 screws in the corners of the reflector secure the reflector to the bracket. And 3 screws in the center of the reflector secure the LED board to the reflector.

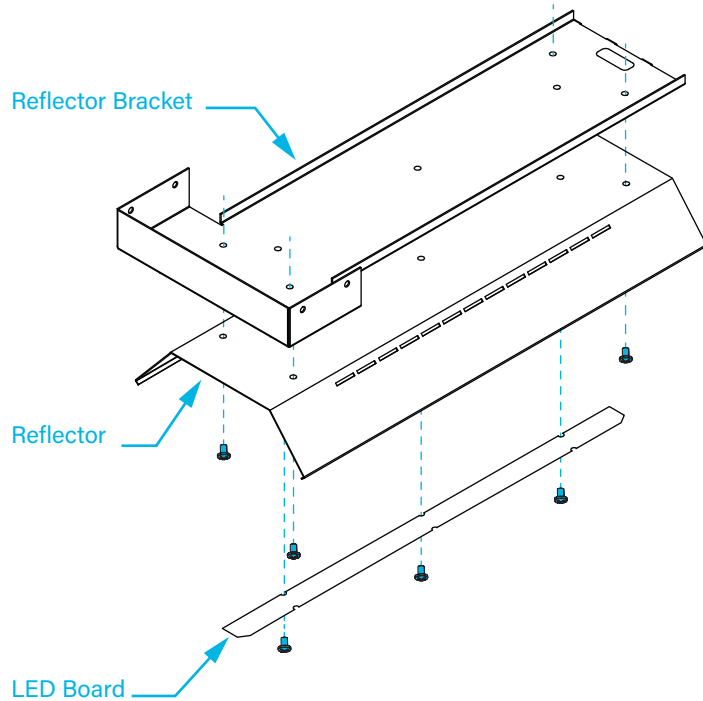

## 2 LED EXTENSION INSTALLATION

Install the LED reflector assembly as shown below using (4) screws/rivets from the kit. Secure the parts in the top row of holes when viewing from a room view perspective. (note: the LED board in the extension box will sit "above", when viewing from a room side, the main fixture's LED board.)

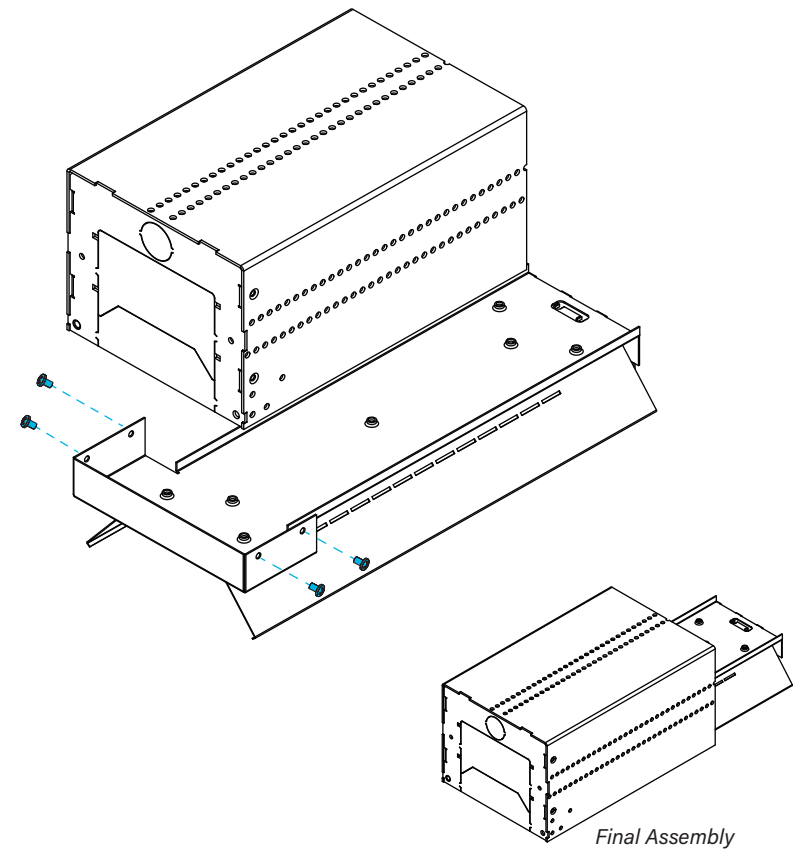





**1 EXTENSION BOX INSTALLATION**

Take the illuminated extension and connect the LED wires to the wires protruding from the main fixture. It is recommended to store any excess wiring in extension box. Slide the extension in between the rails and flush with fixture housing. Secure housing and extension together using two screws one for each side of the bracket.

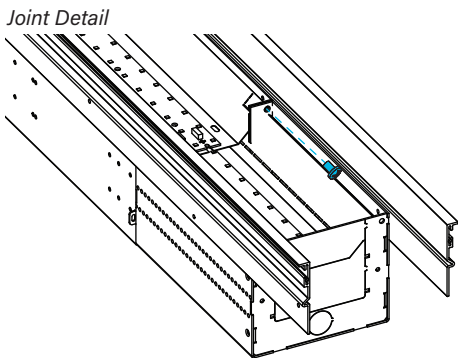
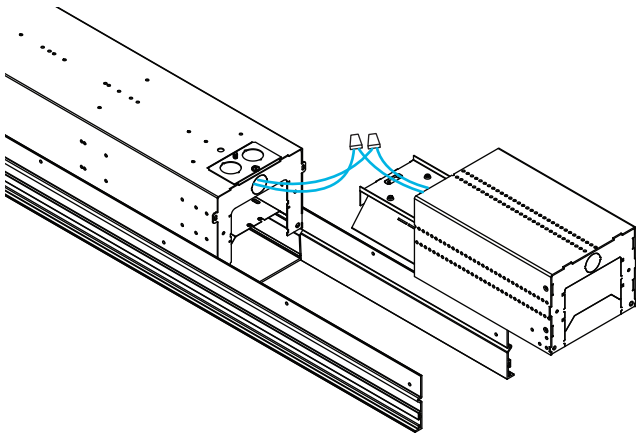

**2 RAIL TRIMMING**

Finish securing of extension to housing with two (2) additional screws, one for each side of the fixture. Once extension is full secured to main fixture trim the excess rails to be flush with end of extension. Once rails and extension box are flush install end cap with 2 screws to finish housing.

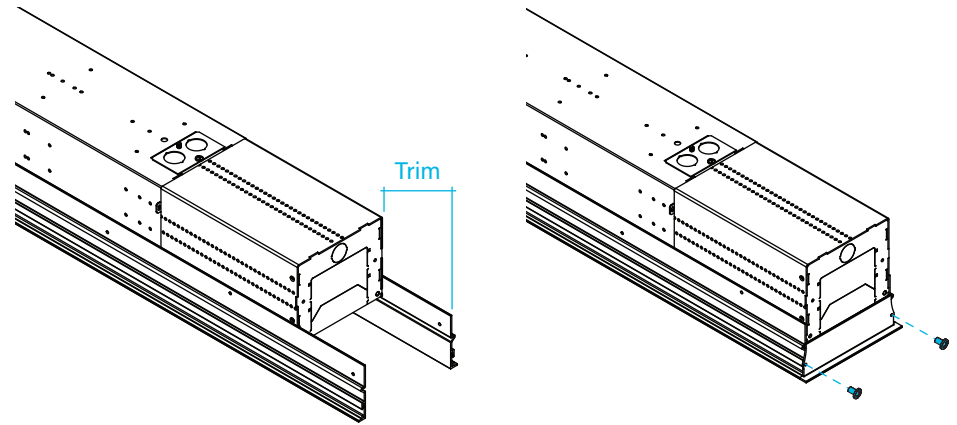



**1 TRIM LENS AND INSTALL**

Select and measure the desired lens length. The lens included in the kits are longer than required. Lens material expands with the heat of the LED boards. Run the saw at full speed and cut the lens slowly to avoid fracture and/or cracking. To account for this, subtract 1/32" from the total desired fixture length to account for thermal expansion.

*(i.e. 96" fixture takes a total or combined lens length of 95.969")*

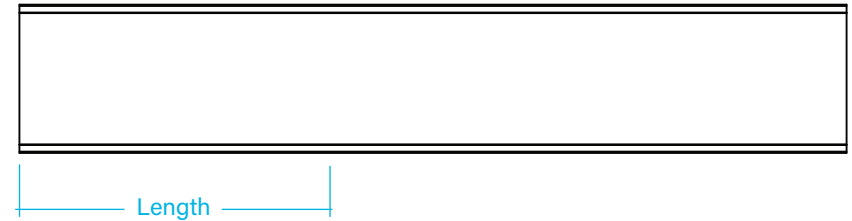
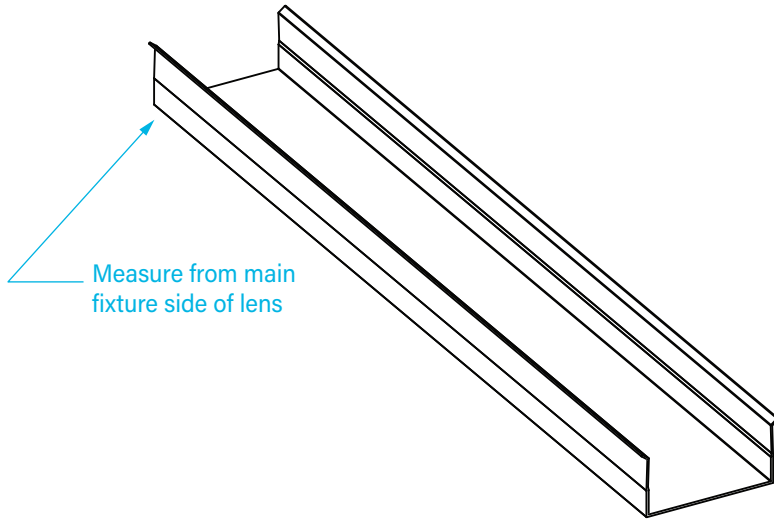

**DISCLAIMERS**

A carbide tipped saw blade for aluminum is recommended for cutting the extension box.

An AGE MD12-962 Industrial Carbide tipped plastic saw blade is recommended for cutting the lens.



### FIELD CUTTABLE EXTENSION UNIT BREAKDOWN

Below are the component pieces required for adjusting and installing the extension. Component pieces are located in the fixture box.

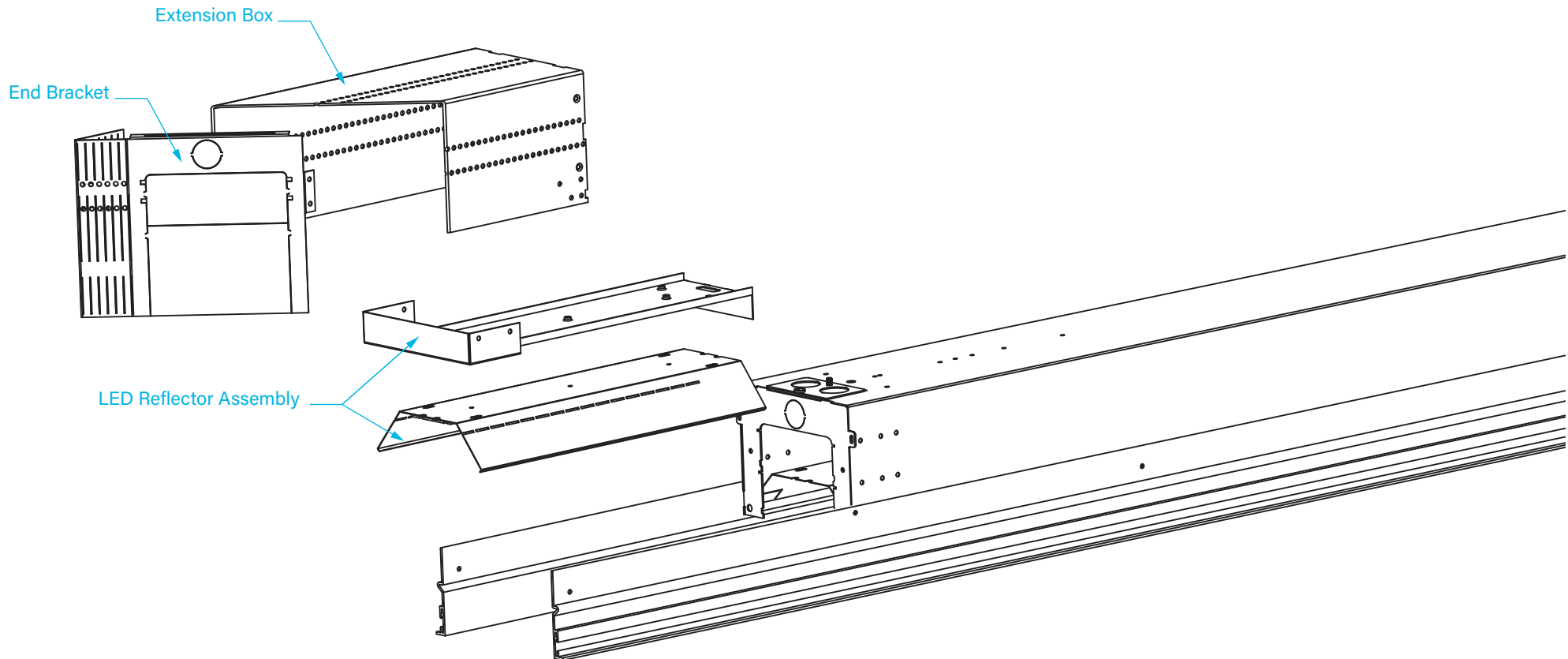



**1 EXTENSION BOX PREP**

Measure the desired length and angle of the final assembled fixture (Extension Box + Main Fixture). Measure the required length from the end of the extension box. Make sure to measure from the end that attached to the main fixture.

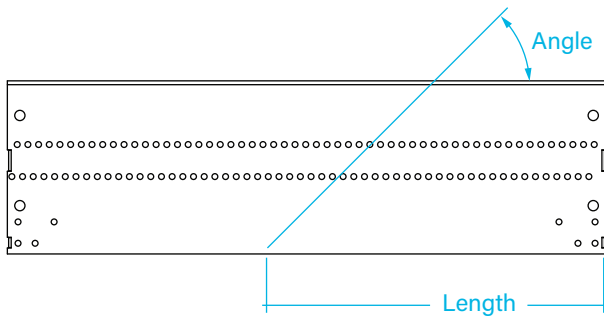
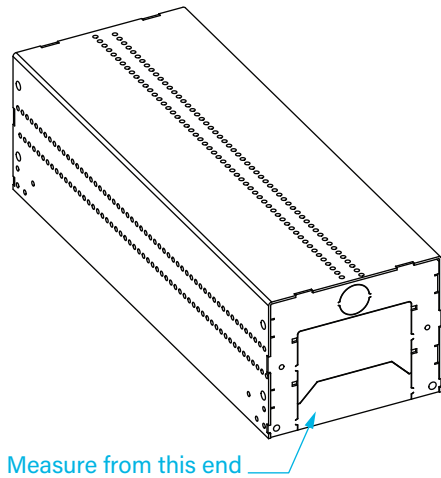

**2 END BRACKET SETUP**

After cutting the extension box, locate end bracket. Fold the end brackets's tabs to a position that will minimize the gap between the extension box and the end bracket. The additional tabs may be cut if desired.

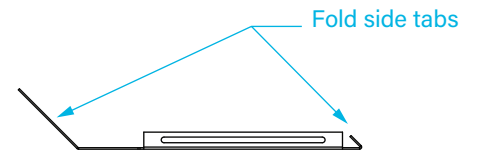
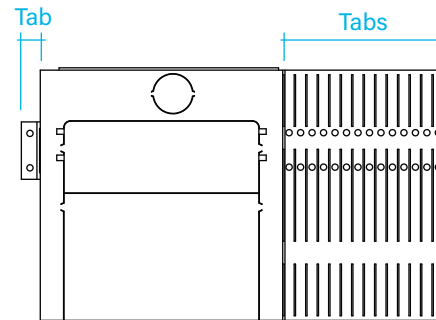



**1 EXTENSION BOX ASSEMBLY**

Secure the end bracket to the cut end of the extension box. Utilize 3 screws/rivets from kit and place them in the locations as shown below.

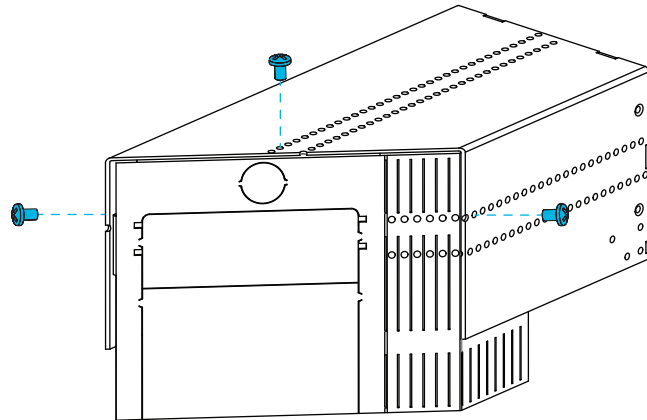

**2 LED EXTENSION INSTALLATION**

Install the LED board and reflector assembly as shown below using (4) screws/rivets from the kit. Secure the parts in the top row of holes when viewing from a room view perspective. *(note: the LED board in the extension box will sit "above", when viewing from a room side, the main fixture's LED board.)*

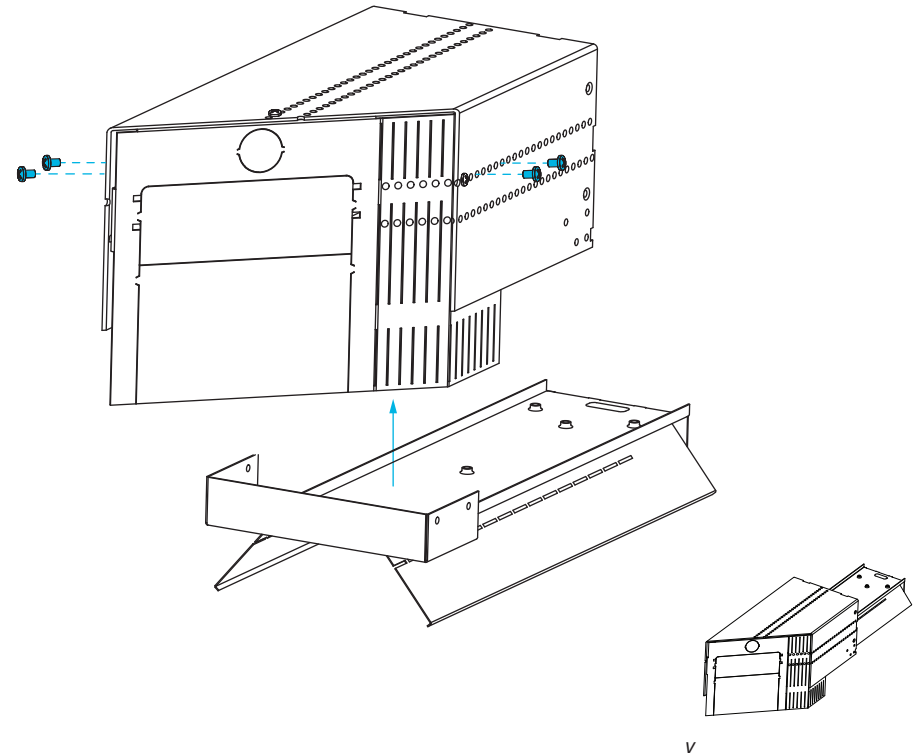



**1 EXTENSION BOX INSTALLATION**

Take the illuminated extension and connect the LED wires to the wires protruding from the main fixture. It is recommended to store any excess wiring in extension box. Slide the extension in between the rails and flush with fixture housing. Secure housing and extension together using two screws one for each side of the bracket.

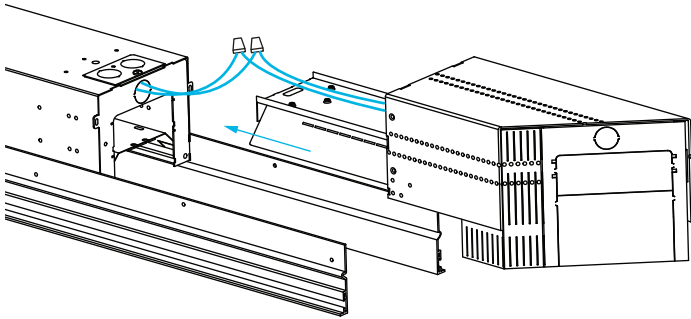

**2 RAIL TRIMMING**

Once extension is installed to main fixture trim the excess rails to be flush with end of extension.

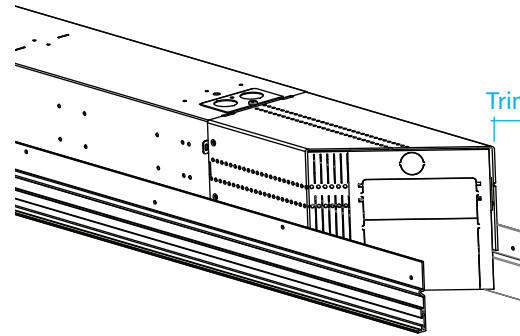

*Joint Detail*

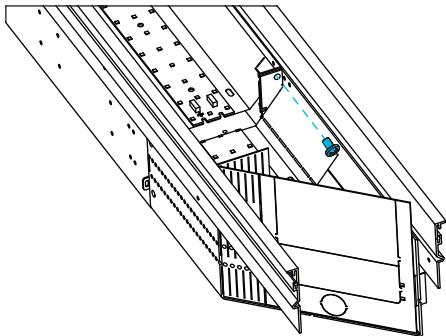



**1 TRIM LENS AND INSTALL**

Select and measure the desired lens length and angle. The lens included in the kits are longer than required. Lens material expands with the heat of the LED boards. Run the saw at full speed and cut the lens slowly to avoid fracture and/or cracking. To account for this, subtract 1/32" from the total desired fixture length to account for thermal expansion.

*(i.e. 96" fixture takes a total or combined lens length of 95.969")*

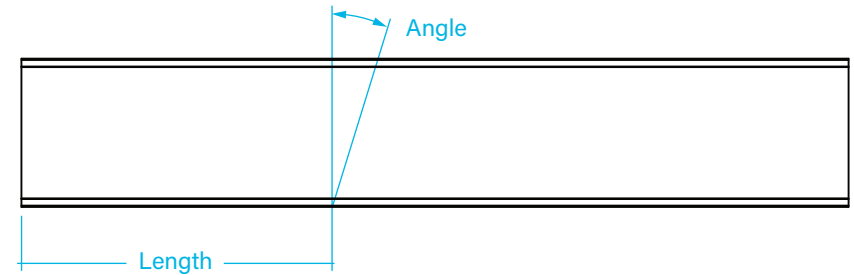
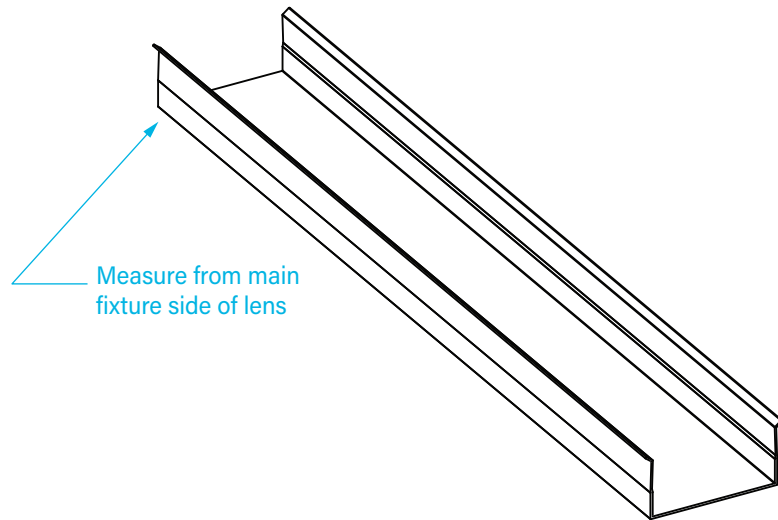

**DISCLAIMERS**

A carbide tipped saw blade for aluminum is recommended for cutting the extension box.

An AGE MD12-962 Industrial Carbide tipped plastic saw blade is recommended for cutting the lens.



*Note: Low temperatures can effect the lens material making it brittle. Please allow the lenses to warm to room temperature before installation.*

**1 LENS INSTALLATION**

Beginning at one end, squeeze lens legs and slide into fixture. Slowly insert rest of lens down the length of the fixture, snapping into place. At fixture end, use putty knife to hold light diffuser in place while snapping lens in.

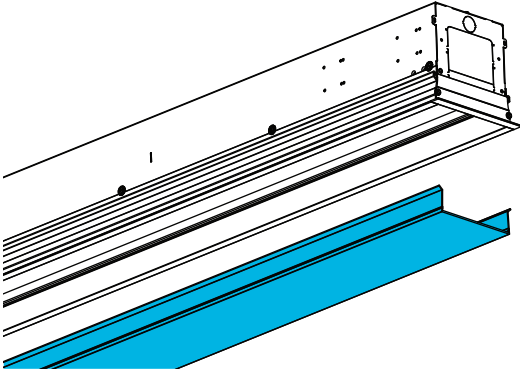

**2 LENS REMOVAL**

Insert a putty knife into the edge between the lens and the fixture side about one inch from end. Gently pry lens away from fixture, using caution not to damage light diffuser at fixture end.

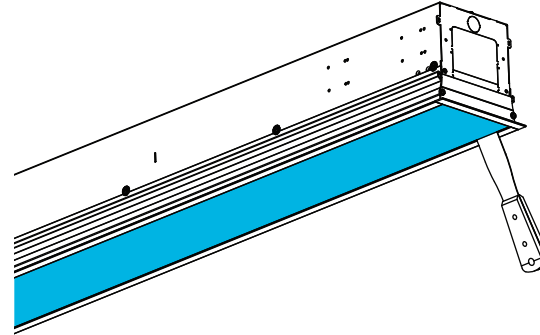

**DISCLAIMERS**

*All of Pinnacle's packaging is recyclable with the exception of the straps on the pallets. Please reach out to the factory if you need assistance in recycling any packaging components.  
A carbide tipped saw blade for aluminum is recommended for cutting the extension box.  
An AGE MD12-962 Industrial Carbide tipped plastic saw blade is recommended for cutting the lens.  
This product must be installed in accordance with applicable installation and electrical codes by a professional familiar with the construction and operation of the product.*

*Minimum 90° C supply conductor.  
All electrical connections must be performed by a certified electrician to applicable local and national electrical codes.  
Damaged components must never be used.  
Contact Pinnacle prior to making any fixture alterations.  
Contact Pinnacle with any installation questions or field issues.*