



EDGE TECH X

For use with Armstrong® TechZone® and
USG Logix™ Integrated Ceiling Systems



T5, T5HO, T8 RECESSED LINEAR DIRECT / Acrylic Lens

MEDIUM SPACE 35'-6" x 35'-6"

ROOM PARAMETERS

Reflectances: ceiling - 80%
walls - 50%
floor - 20%

Light Loss Factor: T5/T5HO 0.81
T8 0.71

Ballast Factor, Lamp Lumen Depreciation & Luminaire Dirt Depreciation

Workplane (2'-6") Calculation

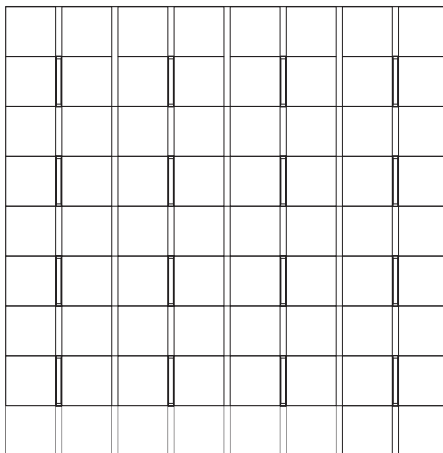
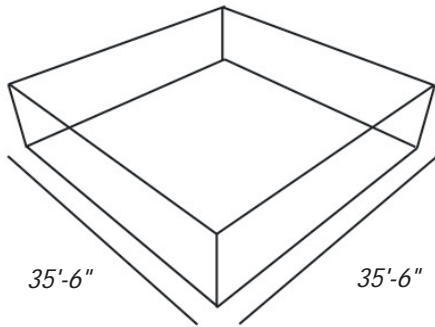

48" Square Tile 6" Fixture Trough
8'-0" & 9'-0" OC Fixture Spacing
Open Space

Ceiling Height

	1T5 28w	1T5HO 54w	1T8 32w	
8'	Average:	18.8 fc	32.5 fc	14.4 fc
	Maximum:	26.0 fc	45.0 fc	20.0 fc
	Minimum:	9.0 fc	15.0 fc	7.0 fc
	Avg/Min Ratio:	2.09	2.17	2.06
9'	Average:	18.1 fc	31.24 fc	13.9 fc
	Maximum:	24.0 fc	41.0 fc	18.0 fc
	Minimum:	9.0 fc	16.0 fc	7.0 fc
	Avg/Min Ratio:	2.01	1.95	1.98
10'	Average:	17.4 fc	30.0 fc	13.3 fc
	Maximum:	22.0 fc	38.0 fc	17.0 fc
	Minimum:	9.0 fc	16.0 fc	7.0 fc
	Avg/Min Ratio:	1.93	1.87	1.90
Lighting Power Density WPSF	.401	.776	.376	
	2T5 28w	2T5HO 54w	2T8 32w	
8'	Average:	35.7 fc	61.4 fc	26.5 fc
	Maximum:	49.0 fc	84.0 fc	36.0 fc
	Minimum:	17.0 fc	29.0 fc	12.0 fc
	Avg/Min Ratio:	2.10	2.12	2.21
9'	Average:	34.2 fc	59.0 fc	25.4 fc
	Maximum:	45.0 fc	77.0 fc	33.0 fc
	Minimum:	17.0 fc	29.0 fc	13.0 fc
	Avg/Min Ratio:	2.01	2.03	1.95
10'	Average:	32.8 fc	56.6 fc	24.4 fc
	Maximum:	42.0 fc	72.0 fc	31.0 fc
	Minimum:	17.0 fc	29.0 fc	13.0 fc
	Avg/Min Ratio:	1.93	1.95	1.87
Lighting Power Density WPSF	.814	1.515	.739	

NOTES: * This application is not recommended
Partitions will reduce light levels up to 25%



EDGE TECH X

For use with Armstrong® TechZone® and
USG Logix™ Integrated Ceiling Systems



T5, T5HO, T8 RECESSED LINEAR DIRECT / Parabolic Louver

MEDIUM SPACE 35'-6" x 35'-6"

ROOM PARAMETERS

Reflectances: ceiling - 80%
walls - 50%
floor - 20%

Light Loss Factor: T5/T5HO 0.81
T8 0.71

Ballast Factor, Lamp Lumen Depreciation & Luminaire Dirt Depreciation

Workplane (2'-6") Calculation

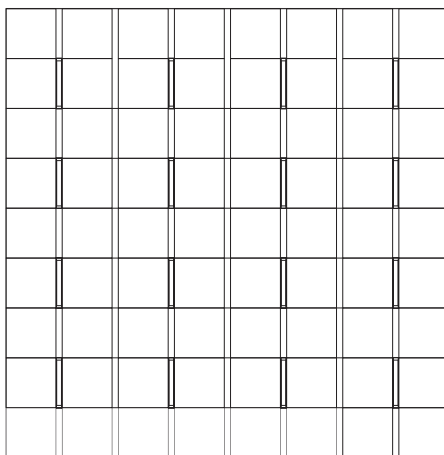
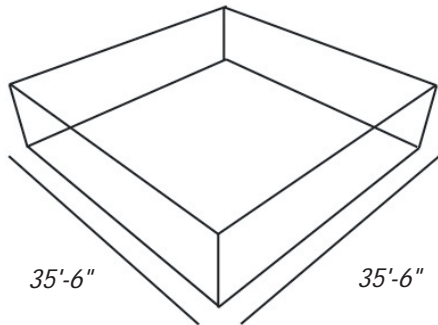

48" Square Tile 6" Fixture Trough
8'-0" & 9'-0" OC Fixture Spacing
Open Space

Ceiling Height

	1T5 28w	1T5HO 54w	1T8 32w	
8'	Average:	21.6 fc	37.3 fc	16.5 fc
	Maximum:	27.0 fc	47.0 fc	22.0 fc
	Minimum:	9.0 fc	15.0 fc	7.0 fc
	Avg/Min Ratio:	2.40	2.48	2.36
9'	Average:	20.9 fc	36.0 fc	16.0 fc
	Maximum:	27.0 fc	47.0 fc	20.0 fc
	Minimum:	9.0 fc	15.0 fc	7.0 fc
	Avg/Min Ratio:	2.32	2.40	2.28
10'	Average:	20.2 fc	34.8 fc	15.4 fc
	Maximum:	26.0 fc	46.0 fc	20.0 fc
	Minimum:	9.0 fc	15.0 fc	7.0 fc
	Avg/Min Ratio:	2.25	2.32	2.20
Lighting Power Density WPSF	.401	.776	.376	
	2T5 28w	2T5HO 54w	2T8 32w	
8'	Average:	41.8 fc	72.0 fc	31.3 fc
	Maximum:	55.0 fc	* 94.0 fc	44.0 fc
	Minimum:	16.0 fc	28.0 fc	12.0 fc
	Avg/Min Ratio:	2.61	2.57	2.60
9'	Average:	40.4 fc	69.7 fc	30.2 fc
	Maximum:	51.0 fc	* 87.0 fc	40.0 fc
	Minimum:	17.0 fc	30.0 fc	13.0 fc
	Avg/Min Ratio:	2.38	2.32	2.32
10'	Average:	39.1 fc	67.4 fc	29.2 fc
	Maximum:	50.0 fc	* 86.0 fc	37.0 fc
	Minimum:	17.0 fc	30.0 fc	13.0 fc
	Avg/Min Ratio:	2.30	2.25	2.25
Lighting Power Density WPSF	.814	1.515	.739	

NOTES: * This application is not recommended
Partitions will reduce light levels up to 25%



EDGE TECH X

For use with Armstrong® TechZone® and
USG Logix™ Integrated Ceiling Systems



T5, T5HO, T8 RECESSED LINEAR DIRECT / Regress Lens

MEDIUM SPACE 35'-6" x 35'-6"

ROOM PARAMETERS

Reflectances: ceiling - 80%
walls - 50%
floor - 20%

Light Loss Factor: T5/T5HO 0.81
T8 0.71

Ballast Factor, Lamp Lumen Depreciation & Luminaire Dirt Depreciation

Workplane (2'-6") Calculation

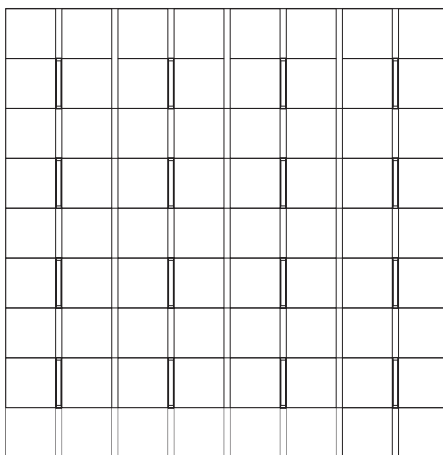
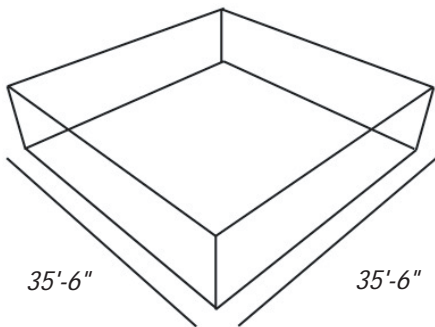

48" Square Tile 6" Fixture Trough
8'-0" & 9'-0" OC Fixture Spacing
Open Space

Ceiling Height

	1T5 28w	1T5HO 54w	1T8 32w	
8'	Average:	19.2 fc	33.2 fc	14.2 fc
	Maximum:	27.0 fc	46.0 fc	20.0 fc
	Minimum:	9.0 fc	15.0 fc	6.0 fc
	Avg/Min Ratio:	2.13	2.21	2.36
9'	Average:	18.5 fc	31.9 fc	13.7 fc
	Maximum:	24.0 fc	42.0 fc	18.0 fc
	Minimum:	9.0 fc	15.0 fc	7.0 fc
	Avg/Min Ratio:	2.05	2.13	1.95
10'	Average:	17.8 fc	30.7 fc	13.1 fc
	Maximum:	23.0 fc	39.0 fc	17.0 fc
	Minimum:	9.0 fc	15.0 fc	7.0 fc
	Avg/Min Ratio:	1.98	2.05	1.88
Lighting Power Density WPSF	.401	.776	.376	
	2T5 28w	2T5HO 54w	2T8 32w	
8'	Average:	36.1 fc	62.3 fc	25.9 fc
	Maximum:	51.0 fc	87.0 fc	36.0 fc
	Minimum:	16.0 fc	28.0 fc	11.0 fc
	Avg/Min Ratio:	2.26	2.23	2.35
9'	Average:	34.8 fc	60.0 fc	24.8 fc
	Maximum:	46.0 fc	79.0 fc	33.0 fc
	Minimum:	17.0 fc	29.0 fc	12.0 fc
	Avg/Min Ratio:	2.04	2.07	2.07
10'	Average:	33.5 fc	57.7 fc	24.0 fc
	Maximum:	43.0 fc	74.0 fc	30.0 fc
	Minimum:	17.0 fc	29.0 fc	12.0 fc
	Avg/Min Ratio:	1.97	1.99	2.00
Lighting Power Density WPSF	.814	1.515	.739	

NOTES: * This application is not recommended
Partitions will reduce light levels up to 25%



EDGE TECH X

For use with Armstrong® TechZone® and
USG Logix™ Integrated Ceiling Systems



T5, T5HO, T8 RECESSED LINEAR DIRECT / Acrylic Lens

SMALL SPACE

18' x 18'

ROOM PARAMETERS

Reflectances: ceiling - 80%
walls - 50%
floor - 20%

Light Loss Factor: T5/T5HO 0.81
T8 0.71

Ballast Factor, Lamp Lumen Depreciation & Luminaire Dirt Depreciation

Workplane (2'-6") Calculation

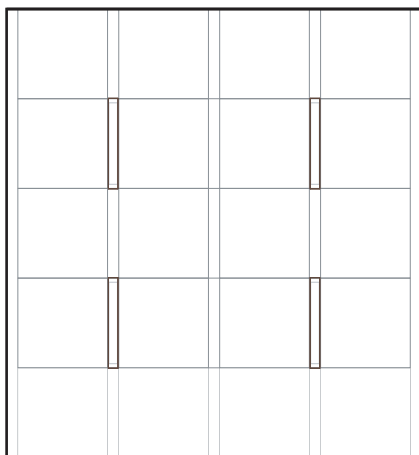
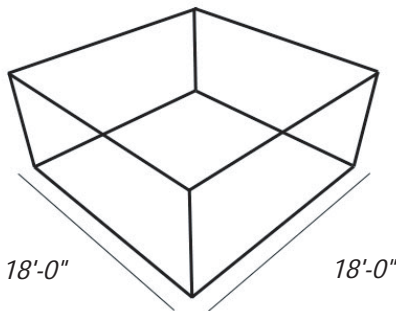

48" Square Tile 6" Fixture Trough
8'-0" & 9'-0" OC Fixture Spacing
Open Space

Ceiling Height

	1T5 28w	1T5HO 54w	1T8 32w	
8'	Average:	14.1 fc	24.4 fc	10.9 fc
	Maximum:	21.0 fc	36.0 fc	16.0 fc
	Minimum:	7.0 fc	12.0 fc	5.0 fc
	Avg/Min Ratio:	2.02	2.03	2.17
9'	Average:	13.1 fc	22.7 fc	10.1 fc
	Maximum:	18.0 fc	31.0 fc	14.0 fc
	Minimum:	7.0 fc	12.0 fc	5.0 fc
	Avg/Min Ratio:	1.87	1.89	2.01
10'	Average:	12.2 fc	21.08 fc	9.3 fc
	Maximum:	16.0 fc	27.0 fc	12.0 fc
	Minimum:	7.0 fc	12.0 fc	5.0 fc
	Avg/Min Ratio:	1.74	1.76	1.87
Lighting Power Density WPSF	.346	.670	.324	
	2T5 28w	2T5HO 54w	2T8 32w	
8'	Average:	26.6 fc	46.0 fc	19.8 fc
	Maximum:	40.0 fc	69.0 fc	30.0 fc
	Minimum:	13.0 fc	22.0 fc	9.0 fc
	Avg/Min Ratio:	2.05	2.09	2.20
9'	Average:	24.8 fc	42.9 fc	18.4 fc
	Maximum:	34.0 fc	59.0 fc	25.0 fc
	Minimum:	13.0 fc	23.0 fc	10.0 fc
	Avg/Min Ratio:	1.91	1.86	1.84
10'	Average:	23.1 fc	39.8 fc	17.2 fc
	Maximum:	30.0 fc	51.0 fc	22.0 fc
	Minimum:	13.0 fc	23.0 fc	10.0 fc
	Avg/Min Ratio:	1.87	1.73	1.72
Lighting Power Density WPSF	.703	1.308	.638	

NOTES: * This application is not recommended
Partitions will reduce light levels up to 25%



EDGE TECH X

For use with Armstrong® TechZone® and
USG Logix™ Integrated Ceiling Systems



T5, T5HO, T8 RECESSED LINEAR DIRECT / Parabolic Louver

SMALL SPACE 18' x 18'

ROOM PARAMETERS

Reflectances: ceiling - 80%
walls - 50%
floor - 20%

Light Loss Factor: T5/T5HO 0.81
T8 0.71

Ballast Factor, Lamp Lumen Depreciation & Luminaire Dirt Depreciation

Workplane (2'-6") Calculation

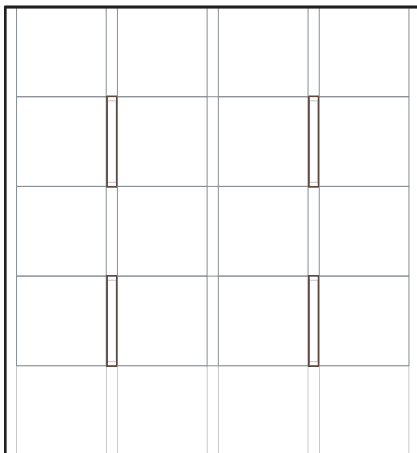
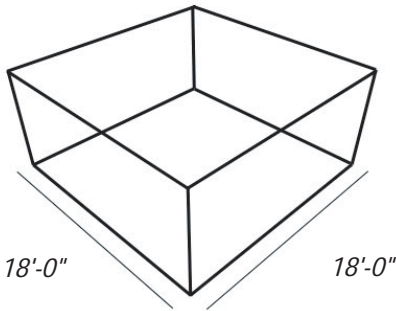

48" Square Tile 6" Fixture Trough
8'-0" & 9'-0" OC Fixture Spacing
Open Space

Ceiling Height

	1T5 28w	1T5HO 54w	1T8 32w	
8'	Average:	16.9 fc	29.1 fc	12.9 fc
	Maximum:	24.0 fc	41.0 fc	19.0 fc
	Minimum:	7.0 fc	12.0 fc	5.0 fc
	Avg/Min Ratio:	2.41	2.43	2.57
9'	Average:	15.8 fc	27.2 fc	12.1 fc
	Maximum:	23.0 fc	39.0 fc	16.0 fc
	Minimum:	8.0 fc	13.0 fc	7.0 fc
	Avg/Min Ratio:	1.97	2.09	2.28
10'	Average:	14.8 fc	25.4 fc	11.3 fc
	Maximum:	21.0 fc	37.0 fc	16.0 fc
	Minimum:	8.0 fc	13.0 fc	6.0 fc
	Avg/Min Ratio:	1.85	1.96	1.89
Lighting Power Density WPSF	.346	.670	.324	
	2T5 28w	2T5HO 54w	2T8 32w	
8'	Average:	32.7 fc	56.2 fc	24.5 fc
	Maximum:	48.0 fc	82.0 fc	39.0 fc
	Minimum:	13.0 fc	23.0 fc	9.0 fc
	Avg/Min Ratio:	2.51	2.44	2.72
9'	Average:	30.6 fc	52.7 fc	23.1 fc
	Maximum:	42.0 fc	72.0 fc	33.0 fc
	Minimum:	14.0 fc	25.0 fc	10.0 fc
	Avg/Min Ratio:	2.19	2.11	2.31
10'	Average:	28.8 fc	49.5 fc	21.8 fc
	Maximum:	40.0 fc	68.0 fc	29.0 fc
	Minimum:	15.0 fc	26.0 fc	11.0 fc
	Avg/Min Ratio:	1.92	1.91	1.96
Lighting Power Density WPSF	.703	1.308	.638	

NOTES: * This application is not recommended
Partitions will reduce light levels up to 25%



EDGE TECH X

For use with Armstrong® TechZone® and
USG Logix™ Integrated Ceiling Systems



T5, T5HO, T8 RECESSED LINEAR DIRECT / Regress Lens

SMALL SPACE

18' x 18'

ROOM PARAMETERS

Reflectances: ceiling - 80%
walls - 50%
floor - 20%

Light Loss Factor: T5/T5HO 0.81
T8 0.71

Ballast Factor, Lamp Lumen Depreciation & Luminaire Dirt Depreciation

Workplane (2'-6") Calculation

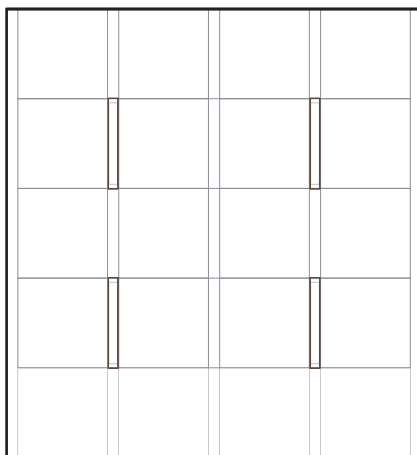
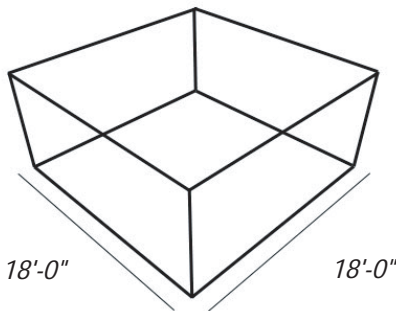

48" Square Tile 6" Fixture Trough
8'-0" & 9'-0" OC Fixture Spacing
Open Space

Ceiling Height

	1T5 28w	1T5HO 54w	1T8 32w	
8'	Average:	14.6 fc	25.2 fc	10.8 fc
	Maximum:	22.0 fc	38.0 fc	16.0 fc
	Minimum:	7.0 fc	11.0 fc	5.0 fc
	Avg/Min Ratio:	2.09	2.29	2.15
9'	Average:	13.6 fc	23.4 fc	10.0 fc
	Maximum:	19.0 fc	32.0 fc	14.0 fc
	Minimum:	7.0 fc	12.0 fc	5.0 fc
	Avg/Min Ratio:	1.94	1.95	2.00
10'	Average:	12.6 fc	21.8 fc	9.4 fc
	Maximum:	16.0 fc	28.0 fc	12.0 fc
	Minimum:	7.0 fc	12.0 fc	5.0 fc
	Avg/Min Ratio:	1.80	1.82	1.87
Lighting Power Density WPSF	.346	.670	.324	
	2T5 28w	2T5HO 54w	2T8 32w	
8'	Average:	27.4 fc	47.2 fc	19.5 fc
	Maximum:	42.0 fc	72.0 fc	30.0 fc
	Minimum:	12.0 fc	21.0 fc	9.0 fc
	Avg/Min Ratio:	2.28	2.25	2.17
9'	Average:	25.6 fc	44.1 fc	18.2 fc
	Maximum:	35.0 fc	61.0 fc	25.0 fc
	Minimum:	13.0 fc	23.0 fc	9.0 fc
	Avg/Min Ratio:	1.97	1.92	2.02
10'	Average:	23.8 fc	41.1 fc	17.1 fc
	Maximum:	31.0 fc	54.0 fc	22.0 fc
	Minimum:	13.0 fc	23.0 fc	9.0 fc
	Avg/Min Ratio:	1.83	1.79	1.90
Lighting Power Density WPSF	.703	1.308	.638	

NOTES: * This application is not recommended
Partitions will reduce light levels up to 25%



EDGE TECH X

For use with Armstrong® TechZone® and USG Logix™ Integrated Ceiling Systems



T5, T5HO, T8 RECESSED LINEAR DIRECT / Acrylic Lens

LINEAR FIXTURE RUN

ROOM PARAMETERS

Reflectances: ceiling - 80%
walls - 50%
floor - 20%

Light Loss Factor: T5/T5HO 0.81
T8 0.71

Ballast Factor, Lamp Lumen Depreciation & Luminaire Dirt Depreciation

Workplane (2'-6") Calculation

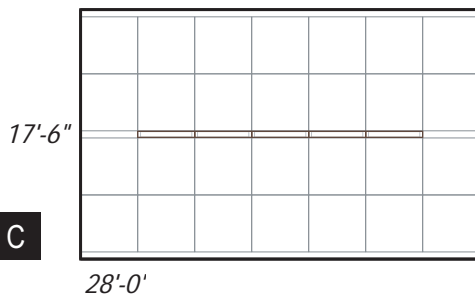
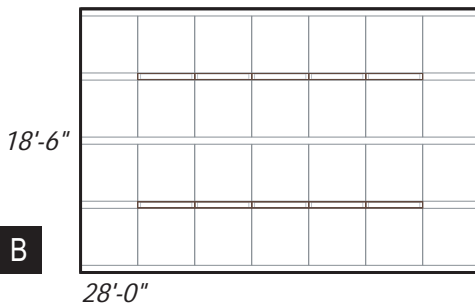
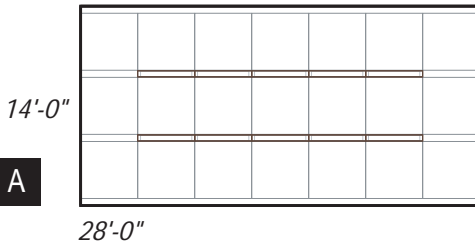

48" Square Tile 6" Fixture Trough
Open Space

		A	1T5 28w	1T5HO 54w	1T8 32w	2T5 28w	2T5HO 54w	2T8 32w
8'	Average:		33.5 fc	57.9 fc	29.1 fc	63.5 fc	109.4 fc	53.51 fc
	Maximum:		57.0 fc	98.0 fc	49.0 fc	108.0 fc	* 185.0 fc	91.0 fc
	Minimum:		12.0 fc	21.0 fc	10.0 fc	23.0 fc	39.0 fc	19.0 fc
	Avg/Min Ratio:		2.79	2.76	2.91	2.76	2.81	2.82
9'	Average:		31.4 fc	54.0 fc	27.1 fc	59.3 fc	102.1 fc	49.9 fc
	Maximum:		51.0 fc	88.0 fc	44.0 fc	97.0 fc	* 166.0 fc	82.0 fc
	Minimum:		13.0 fc	22.0 fc	11.0 fc	24.0 fc	42.0 fc	20.0 fc
	Avg/Min Ratio:		2.41	2.46	2.47	2.47	2.43	2.50
10'	Average:		29.3 fc	50.4 fc	25.5 fc	55.4 fc	95.36 fc	46.7 fc
	Maximum:		46.0 fc	79.0 fc	40.0 fc	87.0 fc	* 149.0 fc	73.0 fc
	Minimum:		13.0 fc	23.0 fc	12.0 fc	25.0 fc	43.0 fc	21.0 fc
	Avg/Min Ratio:		2.25	2.19	2.12	2.22	2.22	2.22
Ceiling Height	LPD/WPSF		.816	1.582	.765	1.658	3.087	1.505
	B	1T5 28w	1T5HO 54w	1T8 32w	2T5 28w	2T5HO 54w	2T8 32w	
8'	Average:		26.5 fc	45.9 fc	23.1 fc	50.3 fc	86.6 fc	42.3 fc
	Maximum:		42.0 fc	72.0 fc	36.0 fc	79.0 fc	* 136.0 fc	67.0 fc
	Minimum:		10.0 fc	18.0 fc	9.0 fc	19.0 fc	33.0 fc	16.0 fc
	Avg/Min Ratio:		2.65	2.55	2.57	2.65	2.62	2.64
9'	Average:		25.0 fc	43.1 fc	21.7 fc	47.3 fc	81.5 fc	39.8 fc
	Maximum:		37.0 fc	64.0 fc	32.0 fc	70.0 fc	* 120.0 fc	59.0 fc
	Minimum:		11.0 fc	19.0 fc	9.0 fc	20.0 fc	35.0 fc	17.0 fc
	Avg/Min Ratio:		2.27	2.27	2.41	2.36	2.33	2.34
10'	Average:		23.5 fc	40.5 fc	20.4 fc	44.0 fc	76.7 fc	37.5 fc
	Maximum:		33.0 fc	57.0 fc	29.0 fc	63.0 fc	* 109.0 fc	53.0 fc
	Minimum:		11.0 fc	19.0 fc	10.0 fc	21.0 fc	36.0 fc	18.0 fc
	Avg/Min Ratio:		2.14	2.13	2.04	2.12	2.13	2.08
Ceiling Height	LPD/WPSF		.618	1.197	.579	1.255	2.336	1.139
	C	1T5 28w	1T5HO 54w	1T8 32w	2T5 28w	2T5HO 54w	2T8 32w	
8'	Average:		15.1 fc	26.2 fc	13.3 fc	28.6 fc	49.5 fc	24.2 fc
	Maximum:		33.0 fc	58.0 fc	29.0 fc	63.0 fc	109.0 fc	53.0 fc
	Minimum:		4.0 fc	8.0 fc	4.0 fc	8.0 fc	14.0 fc	7.0 fc
	Avg/Min Ratio:		3.78	3.28	3.31	3.58	3.54	3.45
9'	Average:		14.2 fc	24.6 fc	12.5 fc	26.9 fc	46.6 fc	22.8 fc
	Maximum:		28.0 fc	49.0 fc	25.0 fc	54.0 fc	93.0 fc	45.0 fc
	Minimum:		5.0 fc	9.0 fc	4.0 fc	9.0 fc	16.0 fc	8.0 fc
	Avg/Min Ratio:		2.84	2.73	3.14	2.99	2.91	2.85
10'	Average:		13.3 fc	23.1 fc	11.7 fc	25.3 fc	43.7 fc	21.3 fc
	Maximum:		24.0 fc	42.0 fc	21.0 fc	46.0 fc	80.0 fc	39.0 fc
	Minimum:		5.0 fc	9.0 fc	5.0 fc	10.0 fc	17.0 fc	8.0 fc
	Avg/Min Ratio:		2.67	2.56	2.34	2.53	2.57	2.66
Ceiling Height	LPD/WPSF		.327	.633	.306	.663	1.235	.602

NOTES: * This application is not recommended
Partitions will reduce light levels up to 25%

ETTA Revision 1.0



EDGE TECH X

For use with Armstrong® TechZone® and USG Logix™ Integrated Ceiling Systems



T5, T5HO, T8 RECESSED LINEAR DIRECT / Parabolic Louver

LINEAR FIXTURE RUN

ROOM PARAMETERS

Reflectances:	ceiling	- 80%
	walls	- 50%
	floor	- 20%

Light Loss Factor: T5/T5HO 0.81
T8 0.71

Ballast Factor, Lamp Lumen Depreciation & Luminaire Dirt Depreciation

Workplane (2'-6") Calculation

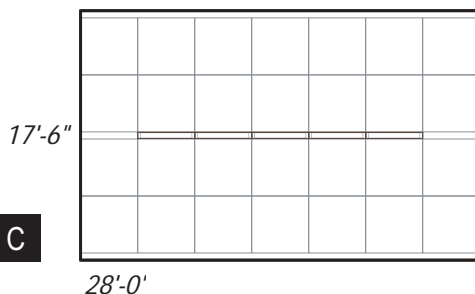
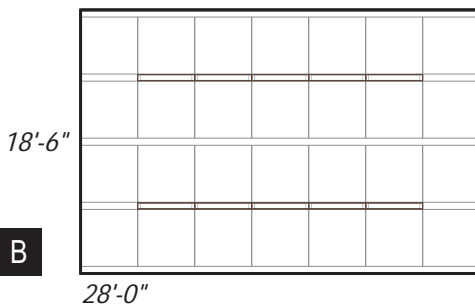
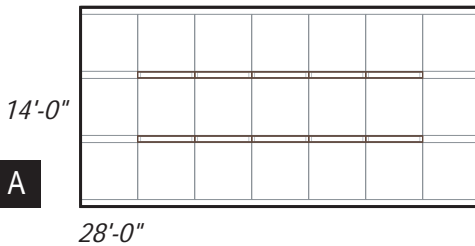

48" Square Tile 6" Fixture Trough
Open Space

		A	1T5 28w	1T5HO 54w	1T8 32w	2T5 28w	2T5HO 54w	2T8 32w
8'	Average:		35.6 fc	66.5 fc	34.9 fc	74.5 fc	128.4 fc	65.9 fc
	Maximum:		70.0 fc	121.0 fc	68.0 fc	139.0 fc	* 239.0 fc	124.0 fc
	Minimum:		11.0 fc	18.0 fc	9.0 fc	20.0 fc	* 34.0 fc	16.0 fc
	Avg/Min Ratio:		3.51	3.69	3.87	3.73	3.78	4.12
9'	Average:		36.2 fc	62.4 fc	33.0 fc	70.3 fc	121.1 fc	62.7 fc
	Maximum:		61.0 fc	105.0 fc	60.0 fc	123.0 fc	* 211.0 fc	113.0 fc
	Minimum:		12.0 fc	21.0 fc	10.0 fc	23.0 fc	* 40.0 fc	19.0 fc
	Avg/Min Ratio:		3.02	2.97	3.30	3.06	3.03	3.30
10'	Average:		34.0 fc	58.5 fc	31.3.0 fc	66.0 fc	113.9 fc	59.2 fc
	Maximum:		54.0 fc	93.0 fc	53.0 fc	108.0 fc	* 187.0 fc	101.0 fc
	Minimum:		14.0 fc	23.0 fc	11.0 fc	26.0 fc	* 44.0 fc	21.0 fc
	Avg/Min Ratio:		2.43	2.55	2.84	2.54	2.59	2.82
Ceiling Height	LPD/WPSF		.816	1.582	.765	1.658	3.087	1.505
	B	1T5 28w	1T5HO 54w	1T8 32w	2T5 28w	2T5HO 54w	2T8 32w	
8'	Average:		30.1 fc	51.9 fc	27.2 fc	58.3 fc	100.5 fc	51.6 fc
	Maximum:		46.0 fc	79.0 fc	43.0 fc	89.0 fc	* 154.0 fc	86.0 fc
	Minimum:		9.0 fc	16.0 fc	8.0 fc	17.0 fc	* 30.0 fc	14.0 fc
	Avg/Min Ratio:		3.35	3.25	3.40	3.43	3.35	3.69
9'	Average:		28.5 fc	49.2 fc	26.0 fc	55.3 fc	95.5 fc	49.3 fc
	Maximum:		46.0 fc	79.0 fc	39.0 fc	83.0 fc	* 144.0 fc	76.0 fc
	Minimum:		10.0 fc	18.0 fc	9.0 fc	19.0 fc	* 34.0 fc	16.0 fc
	Avg/Min Ratio:		2.85	2.73	2.89	2.91	2.81	3.08
10'	Average:		26.9 fc	46.5 fc	24.7 fc	52.5 fc	90.5 fc	48.8 fc
	Maximum:		43.0 fc	74.0 fc	38.0 fc	80.0 fc	* 139.0 fc	69.0 fc
	Minimum:		11.0 fc	19.0 fc	10.0 fc	21.0 fc	* 36.0 fc	18.0 fc
	Avg/Min Ratio:		2.45	2.45	2.47	2.50	2.51	2.60
Ceiling Height	LPD/WPSF		.618	1.197	.579	1.255	2.336	1.139
	C	1T5 28w	1T5HO 54w	1T8 32w	2T5 28w	2T5HO 54w	2T8 32w	
8'	Average:		17.6 fc	30.3 fc	15.7 fc	33.9 fc	58.5 fc	30.0 fc
	Maximum:		37.0 fc	64.0 fc	38.0 fc	76.0 fc	132.0 fc	75.0 fc
	Minimum:		3.0 fc	6.0 fc	3.0 fc	6.0 fc	11.0 fc	5.0 fc
	Avg/Min Ratio:		5.86	5.06	5.26	5.65	5.32	5.99
9'	Average:		16.9 fc	29.0 fc	15.0 fc	32.2 fc	55.8 fc	28.7 fc
	Maximum:		31.0 fc	54.0 fc	32.0 fc	64.0 fc	111.0 fc	64.0 fc
	Minimum:		4.0 fc	8.0 fc	3.0 fc	8.0 fc	14.0 fc	6.0 fc
	Avg/Min Ratio:		4.22	3.62	5.01	4.03	3.99	4.78
10'	Average:		15.8 fc	27.2 fc	14.4 fc	30.5 fc	52.6 fc	27.2 fc
	Maximum:		27.0 fc	46.0 fc	27.0 fc	55.0 fc	95.0 fc	55.0 fc
	Minimum:		5.0 fc	9.0 fc	4.0 fc	10.0 fc	16.0 fc	7.0 fc
	Avg/Min Ratio:		3.15	3.02	3.59	3.05	3.29	3.89
Ceiling Height	LPD/WPSF		.327	.633	.306	.663	1.235	.602

NOTES: * This application is not recommended
Partitions will reduce light levels up to 25%

ETTA Revision 1.0



EDGE TECH X

For use with Armstrong® TechZone® and USG Logix™ Integrated Ceiling Systems



T5, T5HO, T8 RECESSED LINEAR DIRECT / Regress Lens

LINEAR FIXTURE RUN

ROOM PARAMETERS

Reflectances: ceiling - 80%
walls - 50%
floor - 20%

Light Loss Factor: T5/T5HO 0.81
T8 0.71

Ballast Factor, Lamp Lumen Depreciation & Luminaire Dirt Depreciation

Workplane (2'-6") Calculation

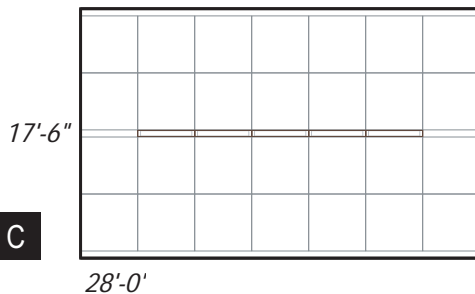
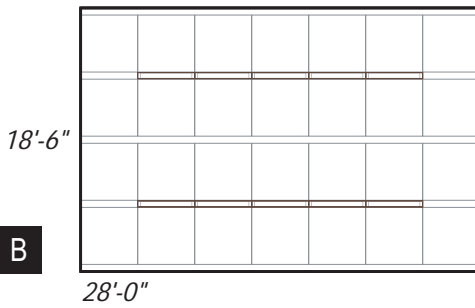
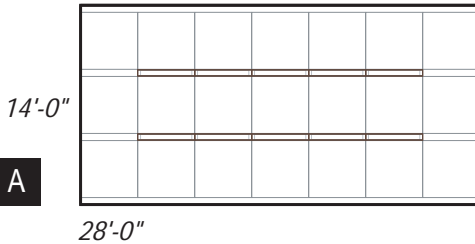

48" Square Tile 6" Fixture Trough
Open Space

		A	1T5 28w	1T5HO 54w	1T8 32w	2T5 28w	2T5HO 54w	2T8 32w
8'	Average:		34.9 fc	60.0 fc	29.1 fc	65.5 fc	112.9 fc	53.1 fc
	Maximum:		61.0 fc	104.0 fc	51.0 fc	114.0 fc	* 197.0 fc	93.0 fc
	Minimum:		12.0 fc	20.0 fc	10.0 fc	22.0 fc	38.0 fc	18.0 fc
	Avg/Min Ratio:		2.91	3.00	2.91	2.98	2.97	2.95
9'	Average:		32.6 fc	56.2 fc	27.3 fc	61.4 fc	105.7 fc	49.7 fc
	Maximum:		54.0 fc	94.0 fc	46.0 fc	102.0 fc	* 177.0 fc	84.0 fc
	Minimum:		13.0 fc	22.0 fc	11.0 fc	24.0 fc	41.0 fc	19.0 fc
	Avg/Min Ratio:		2.51	2.55	2.48	2.56	2.58	2.62
10'	Average:		30.5 fc	52.5 fc	25.7 fc	57.4 fc	99.0 fc	46.6 fc
	Maximum:		49.0 fc	84.0 fc	41.0 fc	92.0 fc	* 159.0 fc	75.0 fc
	Minimum:		13.0 fc	23.0 fc	11.0 fc	25.0 fc	43.0 fc	20.0 fc
	Avg/Min Ratio:		2.35	2.28	2.34	2.30	2.30	2.33
Ceiling Height	LPD/WPSF		.816	1.582	.765	1.658	3.087	1.505
	B	1T5 28w	1T5HO 54w	1T8 32w	2T5 28w	2T5HO 54w	2T8 32w	
8'	Average:		27.4 fc	47.3 fc	22.9 fc	51.6 fc	89.1 fc	41.9 fc
	Maximum:		44.0 fc	76.0 fc	37.0 fc	83.0 fc	* 143.0 fc	67.0 fc
	Minimum:		10.0 fc	17.0 fc	8.0 fc	19.0 fc	32.0 fc	15.0 fc
	Avg/Min Ratio:		2.74	2.78	2.87	2.72	2.78	2.79
9'	Average:		25.8 fc	44.7 fc	21.65 fc	48.8 fc	84.1 fc	39.4 fc
	Maximum:		39.0 fc	67.0 fc	33.0 fc	73.0 fc	* 126.0 fc	59.0 fc
	Minimum:		11.0 fc	18.0 fc	9.0 fc	20.0 fc	35.0 fc	16.0 fc
	Avg/Min Ratio:		2.35	2.48	2.41	2.44	2.40	2.46
10'	Average:		24.4 fc	42.1 fc	20.5 fc	45.9 fc	79.2 fc	37.2 fc
	Maximum:		35.0 fc	60.0 fc	29.0 fc	66.0 fc	* 113.0 fc	53.0 fc
	Minimum:		11.0 fc	19.0 fc	9.0 fc	21.0 fc	36.0 fc	17.0 fc
	Avg/Min Ratio:		2.21	2.22	2.28	2.18	2.20	2.19
Ceiling Height	LPD/WPSF		.618	1.197	.579	1.255	2.336	1.139
	C	1T5 28w	1T5HO 54w	1T8 32w	2T5 28w	2T5HO 54w	2T8 32w	
8'	Average:		15.7 fc	27.1 fc	13.1 fc	29.6 fc	51.0 fc	24.0 fc
	Maximum:		36.0 fc	62.0 fc	30.0 fc	68.0 fc	117.0 fc	55.0 fc
	Minimum:		4.0 fc	7.0 fc	3.0 fc	8.0 fc	13.0 fc	6.0 fc
	Avg/Min Ratio:		3.92	3.88	4.37	3.70	3.92	3.99
9'	Average:		14.8 fc	25.6 fc	12.4 fc	28.0 fc	48.3 fc	22.7 fc
	Maximum:		31.0 fc	53.0 fc	26.0 fc	58.0 fc	99.0 fc	47.0 fc
	Minimum:		5.0 fc	8.0 fc	4.0 fc	9.0 fc	15.0 fc	7.0 fc
	Avg/Min Ratio:		2.96	3.20	3.11	3.11	3.22	3.24
10'	Average:		14.0 fc	24.1 fc	11.6 fc	26.3 fc	45.4 fc	21.3 fc
	Maximum:		26.0 fc	45.0 fc	22.0 fc	49.0 fc	85.0 fc	40.0 fc
	Minimum:		5.0 fc	9.0 fc	4.0 fc	10.0 fc	17.0 fc	8.0 fc
	Avg/Min Ratio:		2.81	2.68	2.90	2.63	2.67	2.66
Ceiling Height	LPD/WPSF		.327	.633	.306	.663	1.235	.602

NOTES: * This application is not recommended
Partitions will reduce light levels up to 25%