

SORREL

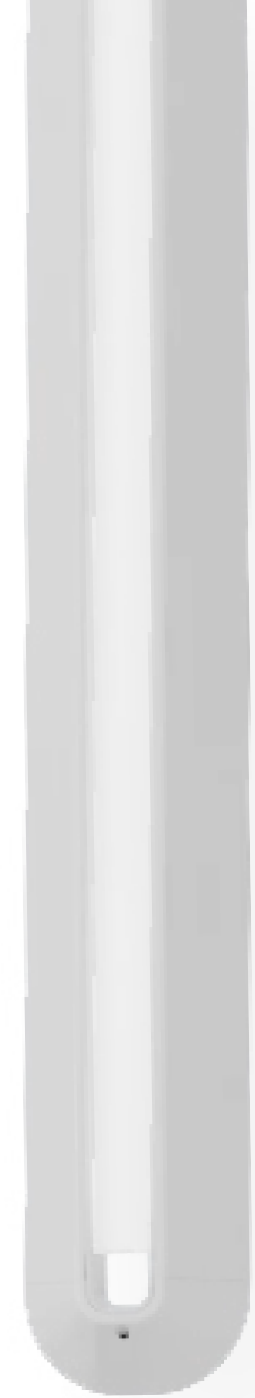

PINNACLE
ARCHITECTURAL LIGHTING®

A brand of  legrand®



D O W N



N E U T R A L



U P



SORREL

O P E N L I G H T

Sorrel is a family of three distinct products where each serves a different distinct application and purpose; **UP** (where the majority of light is upwards for indirect lighting benefits); **DOWN** (where the majority of light is downwards for direct task-oriented work); and **Neutral** where there is an equal balance of upwards and downward illumination in a space.

The basis of design for Sorrel is to evoke an open awareness of light. Dual planes of even illumination lay in parallel form. The center space opening yields a spaciousness that consequently minimizes the overall profile. The open space between the parallel lines of light disguise the form but still provide high levels of illumination.

The structure and body of Sorrel is centered around curvature and softness. Deviating from the traditional rigid, rectilinear shapes, Sorrel offers soft curved corners, soft curved rails, and soft curved edges. This combination creates a gentle and elegant lighting product series.

Lastly, in a world of choices, non-illuminated, yet structurally aligned, connector shapes, allow for endless geometries that help redefine the ceiling plane, and provide design flexibility to place the light exactly where it is intended.

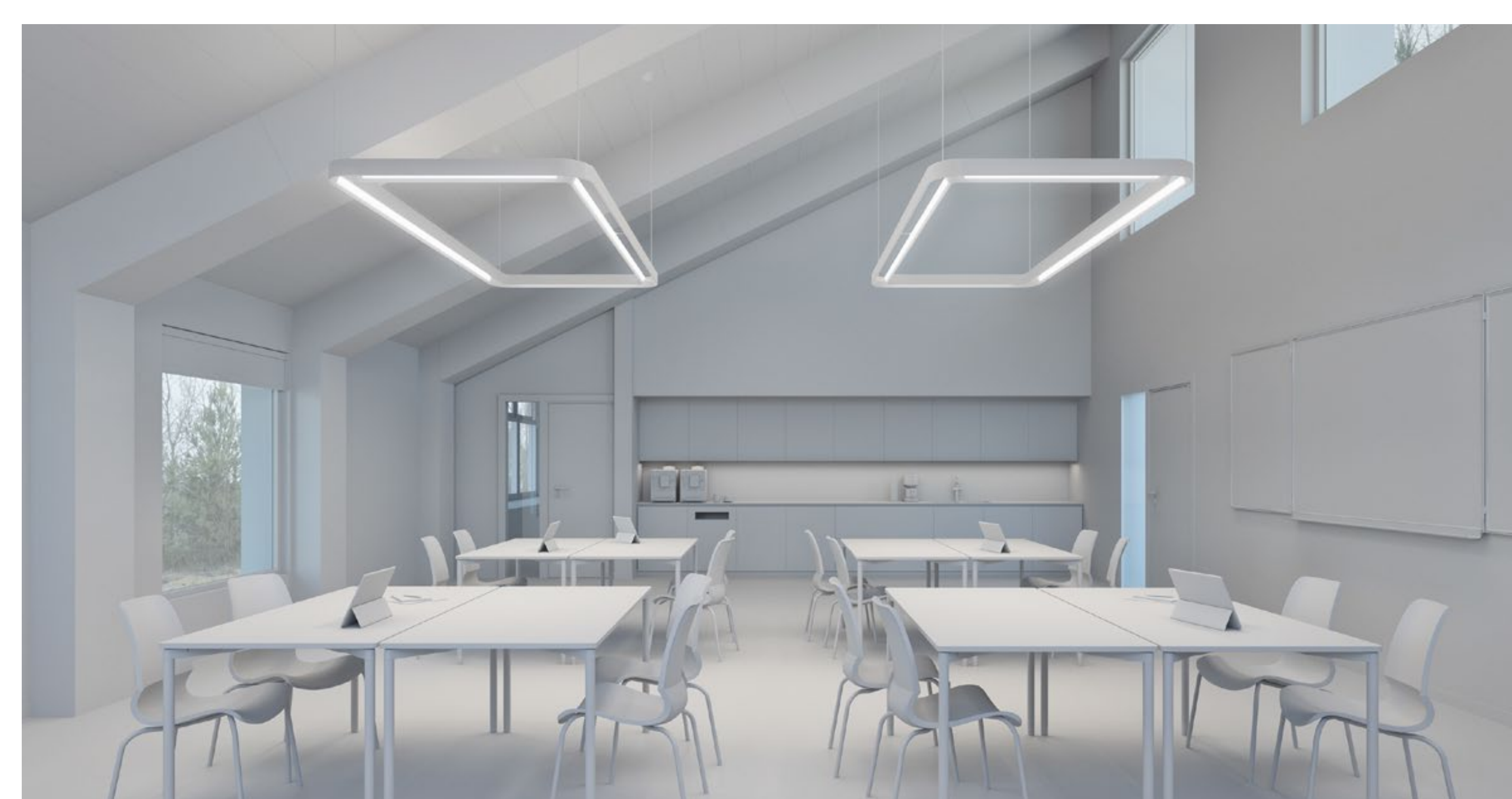

OPEN SPACE · OPEN LIGHT

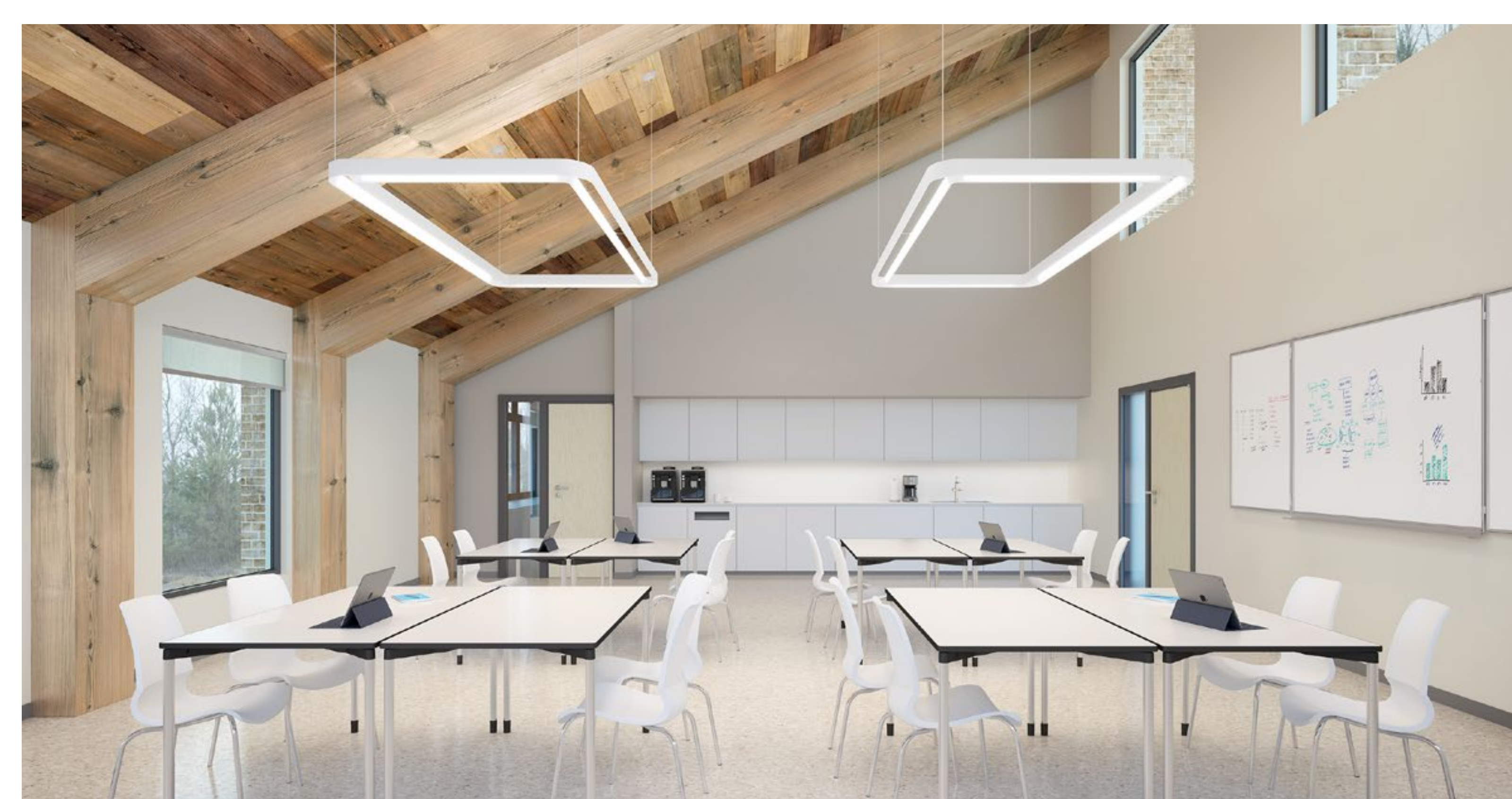

SOFT LINES · SOFT CORNERS · SOFT FORMS

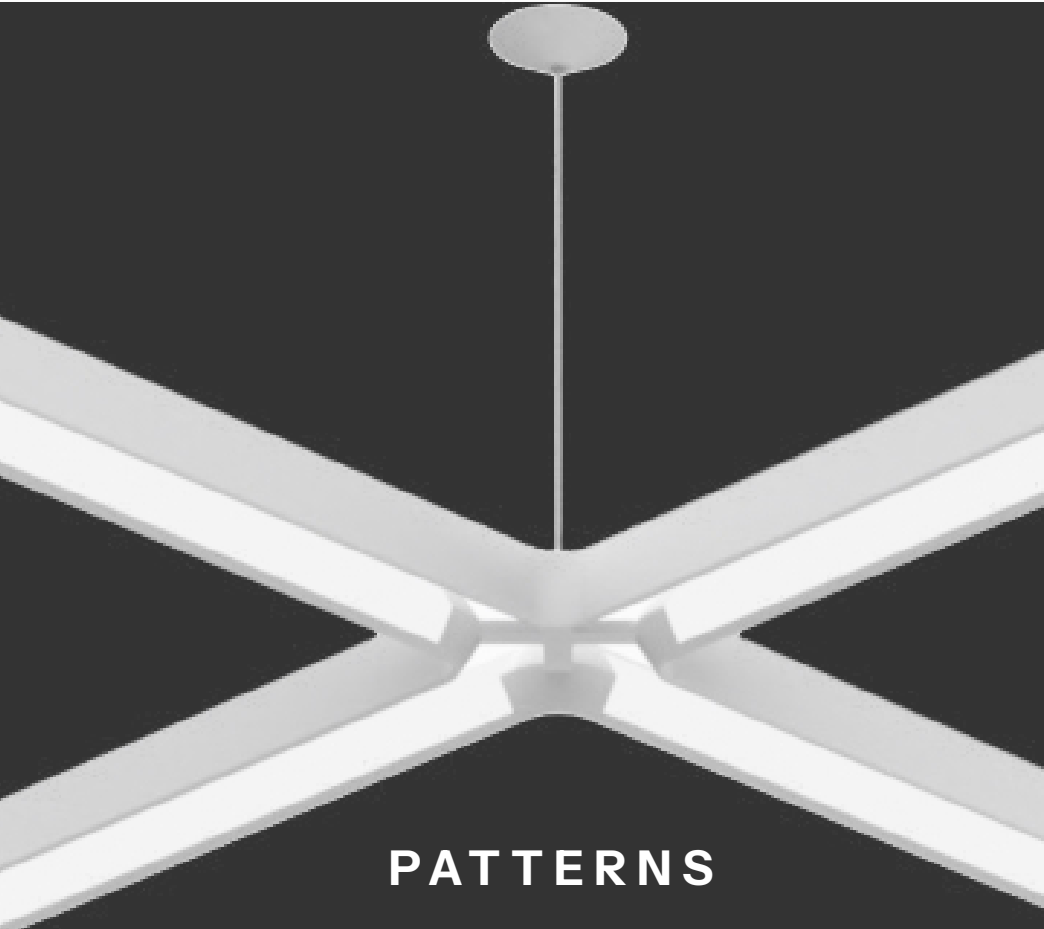

PATTERNS

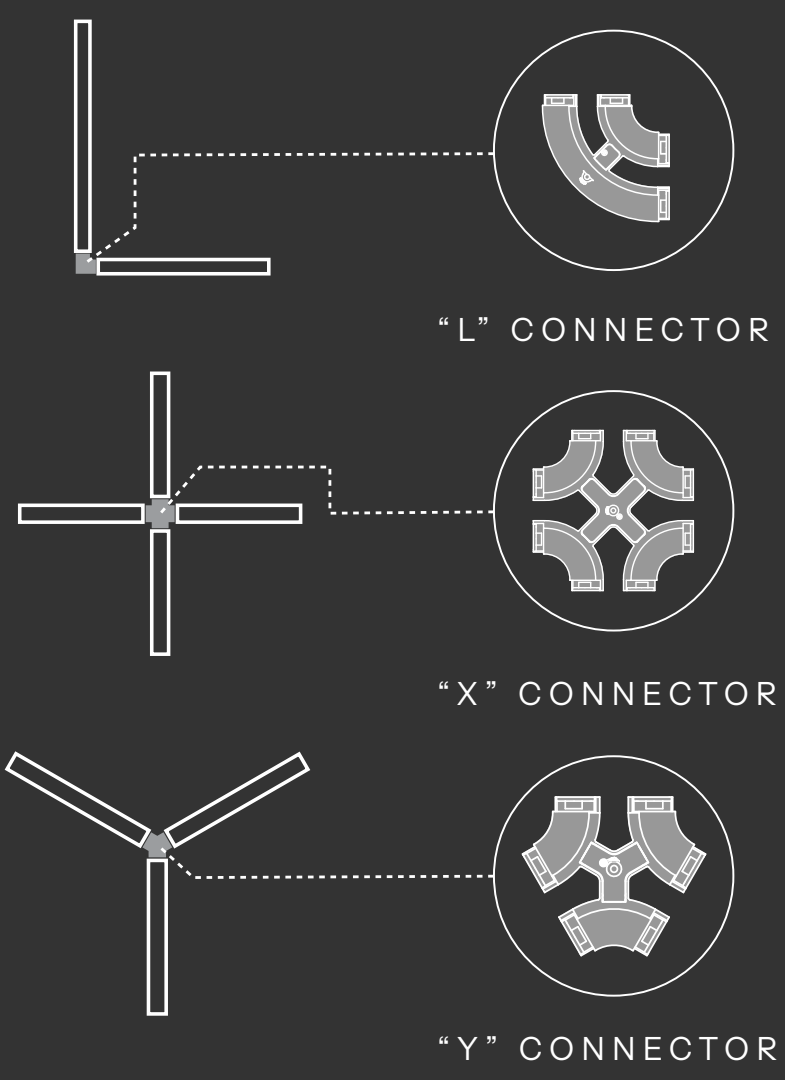

LENGTHS

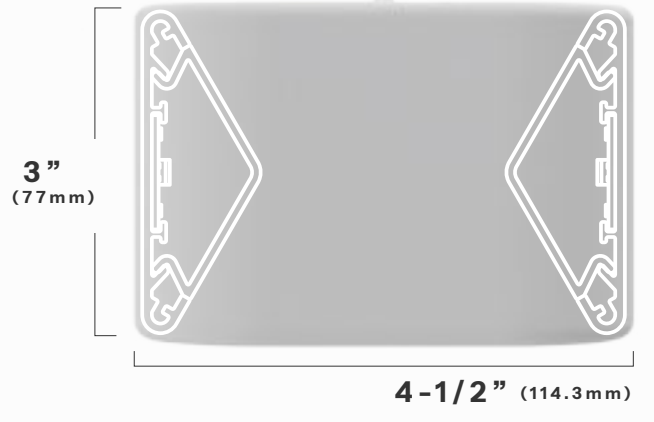
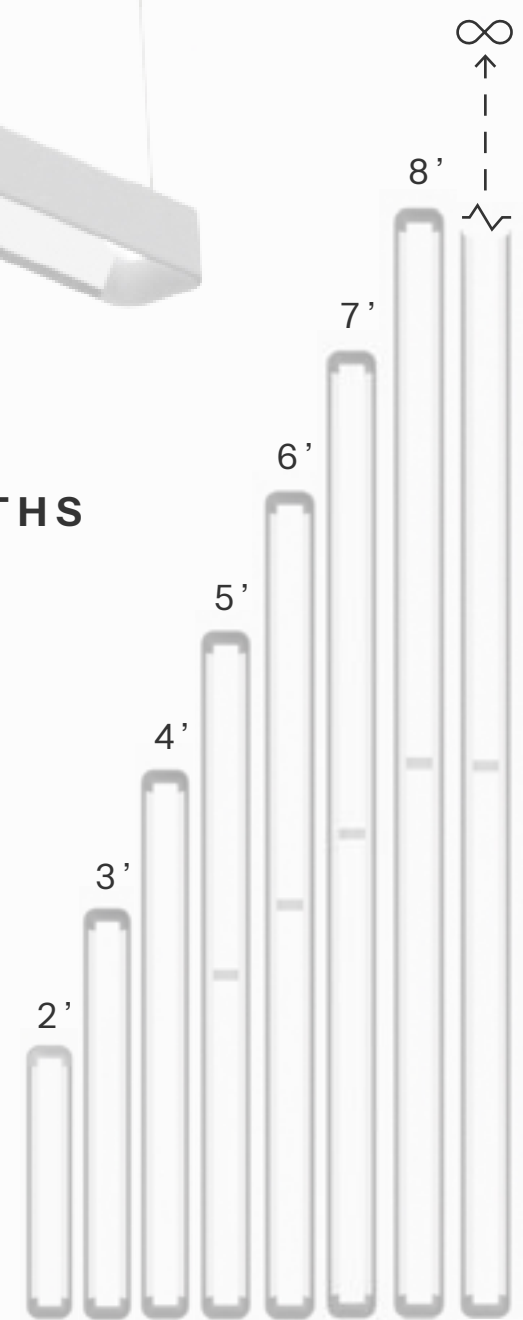

PHOTOMETRIC DISTRIBUTION

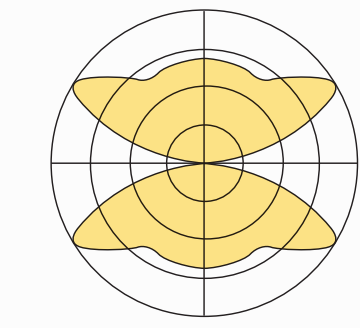

50% UP
50% DOWN



FEATURES

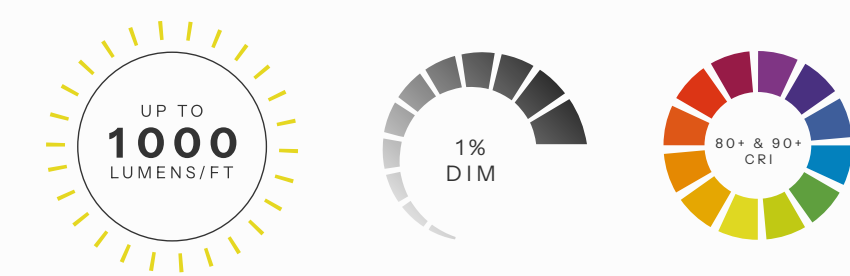

FINISHES



*Colors for representational purpose only. For accurate color please contact the factory for color samples.



N
NEUTRAL

SORREL
NEUTRAL

Sorrel NEUTRAL offers illumination with equal distributions of light to provide general ambient lighting for applications with up to 1250 lms/ ft custom. The dual planes of light offer an equal distribution of light with the softness of shape while providing balanced uniformity.

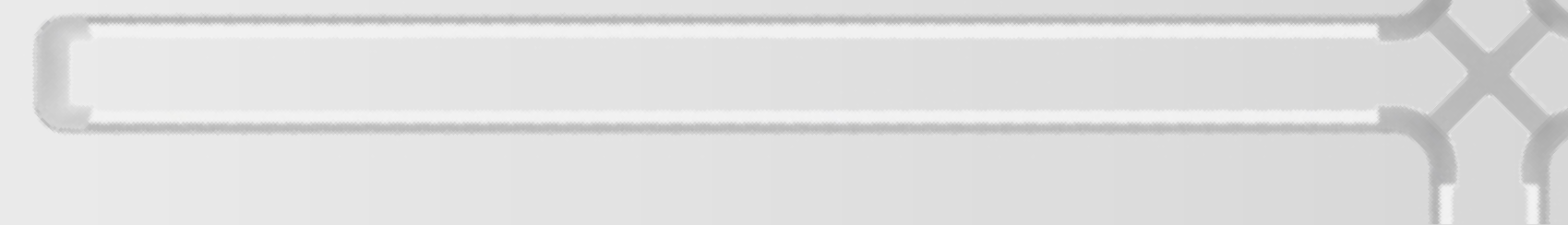



DUAL PLANES OF LIGHT ·
BALANCED ILLUMINATION



FIXED CONNECTORS ·
VARIABLE GEOMETRIES

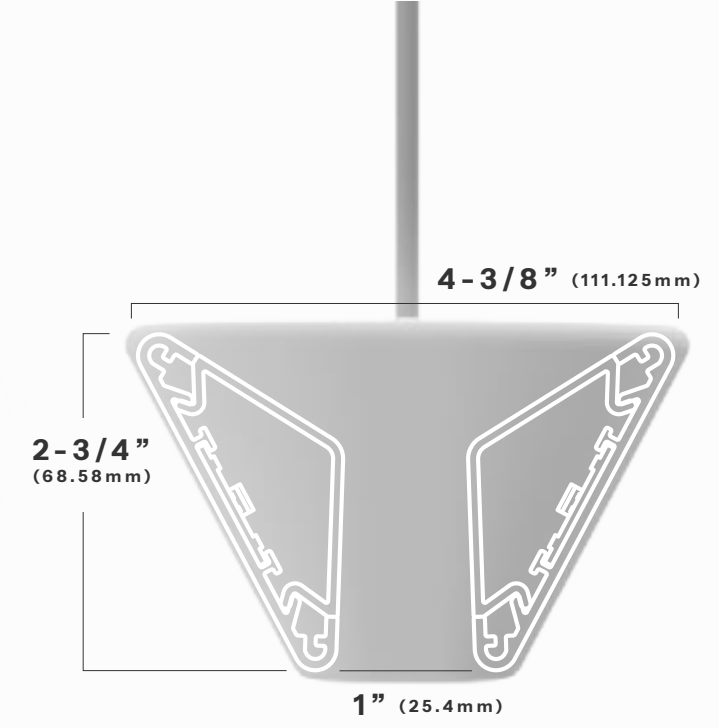
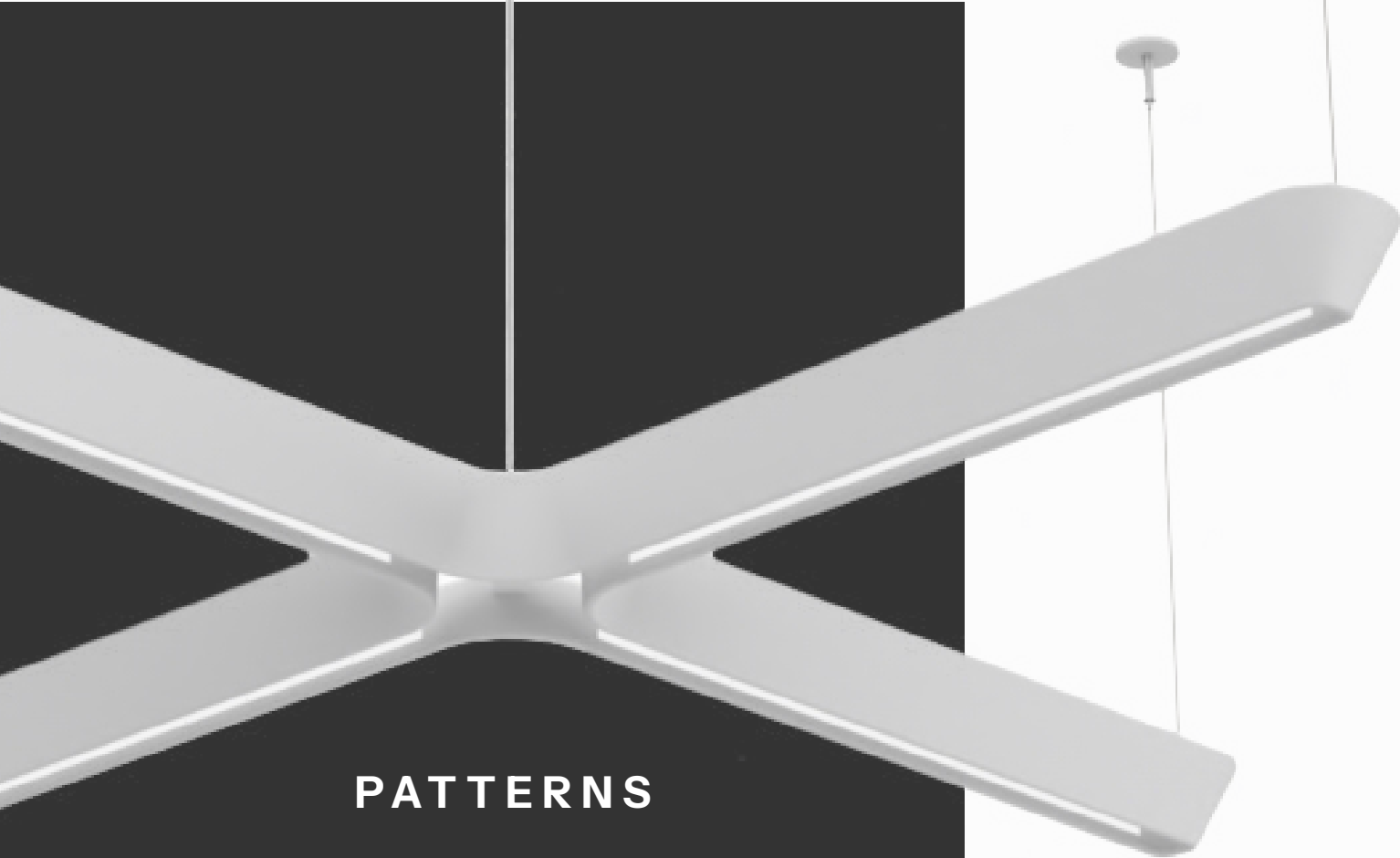

PHOTOMETRIC DISTRIBUTION

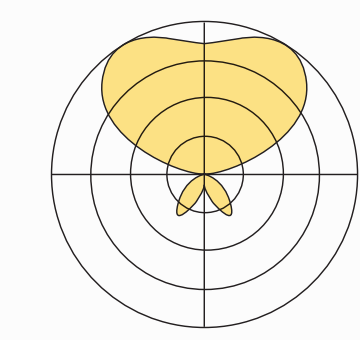

80% UP
20% DOWN



PATTERNS

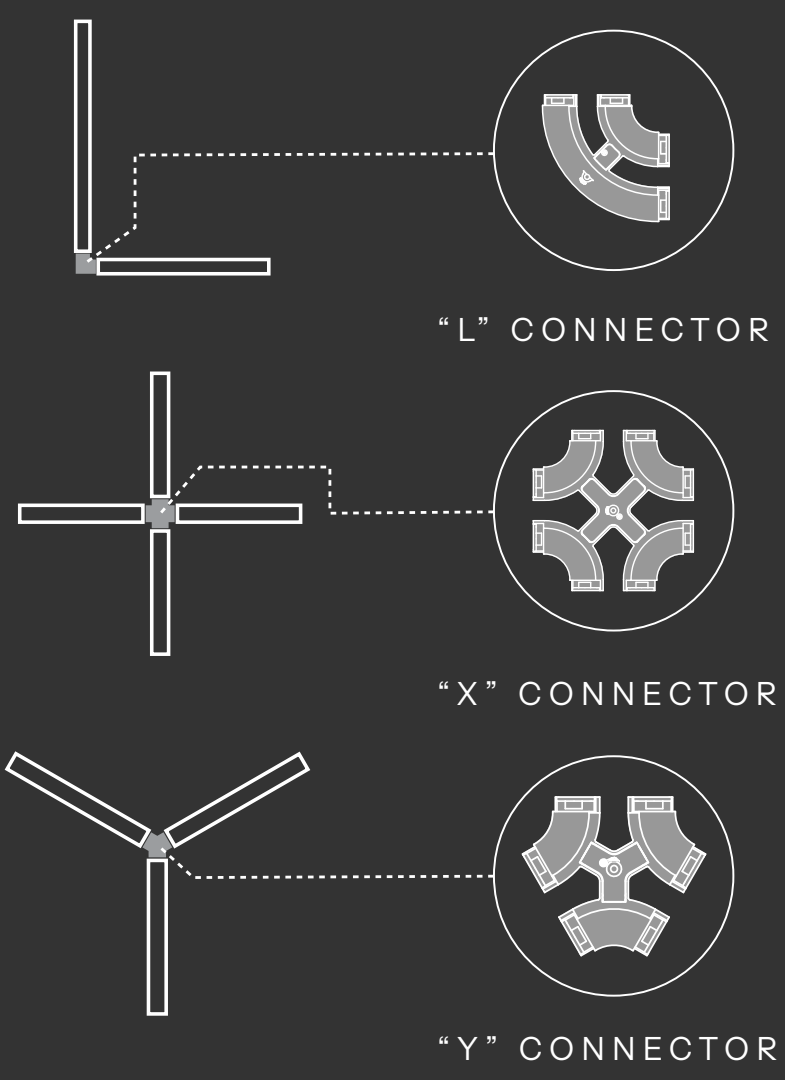

LENGTHS

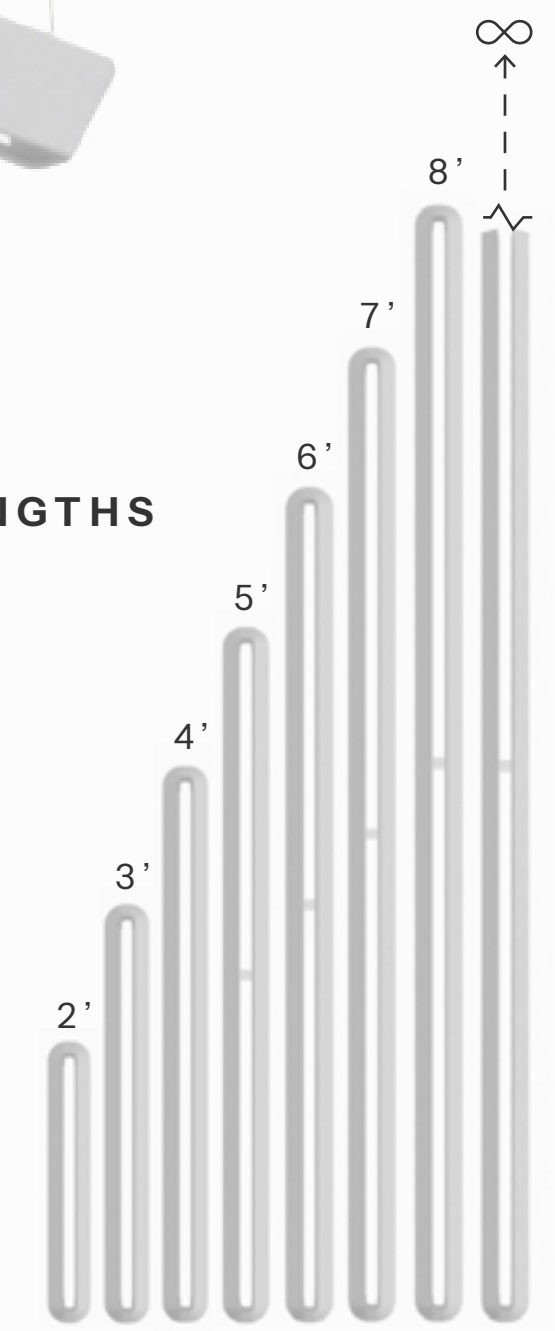

FEATURES

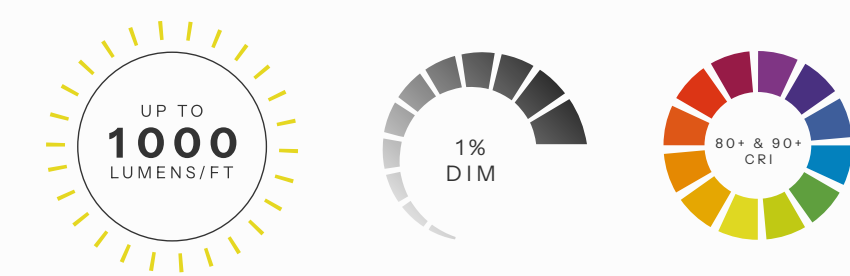

FINISHES



**Colors for representational purpose only. For accurate color please contact the factory for color samples.*



SORREL

UP

Sorrel UP is used for applications that benefit from primarily indirect application needs, where the lighting is 80% uplight/ 20% downlight. With the majority of light upwards, the small amount of light down helps with minimal ambient lighting.



UP





ENDLESS GEOMETRIES

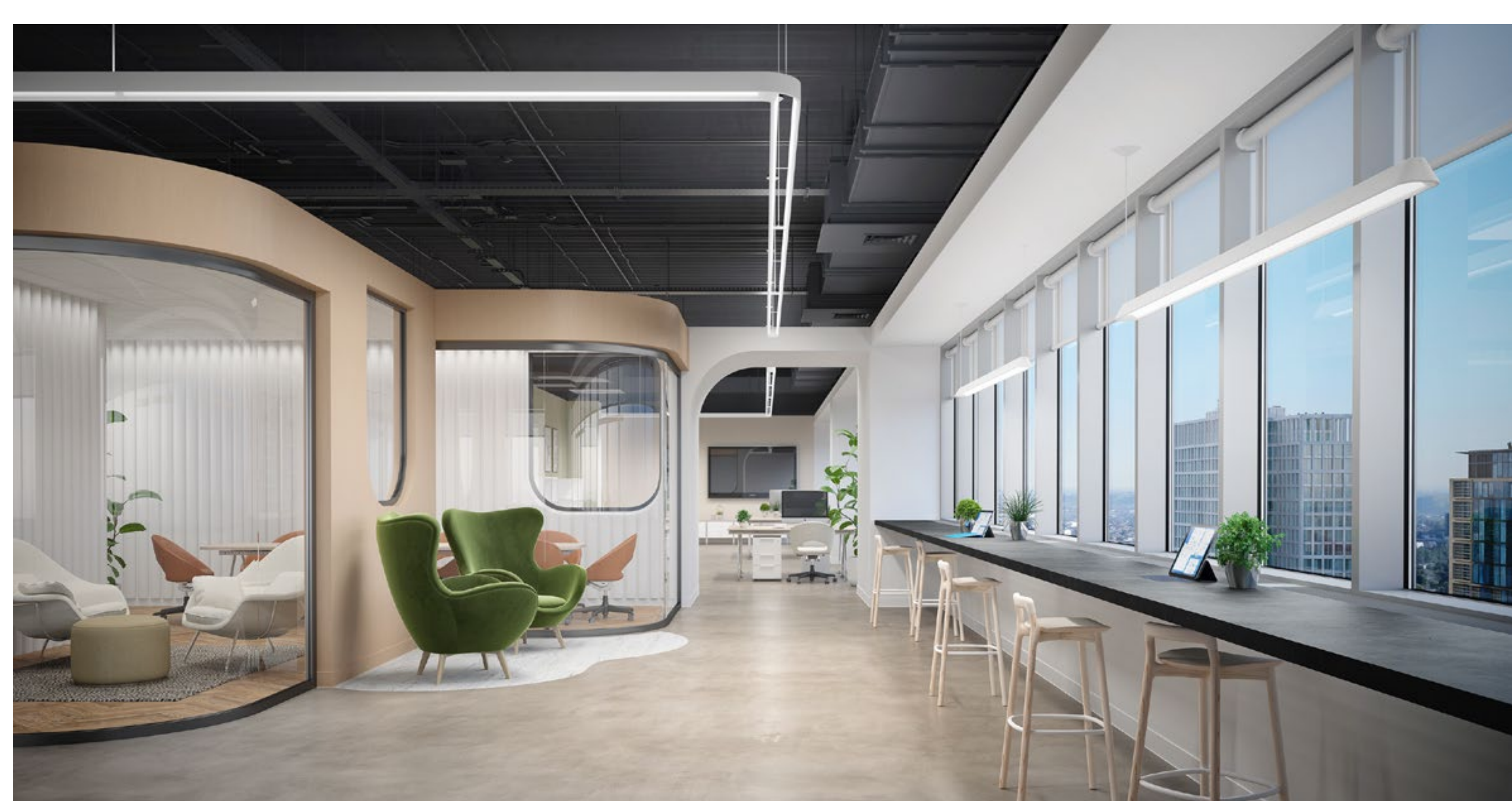

CONFIGURABLE SHAPES

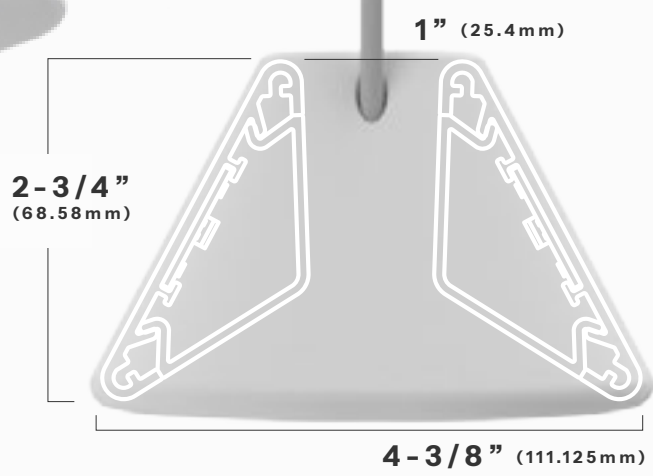

PHOTOMETRIC DISTRIBUTION

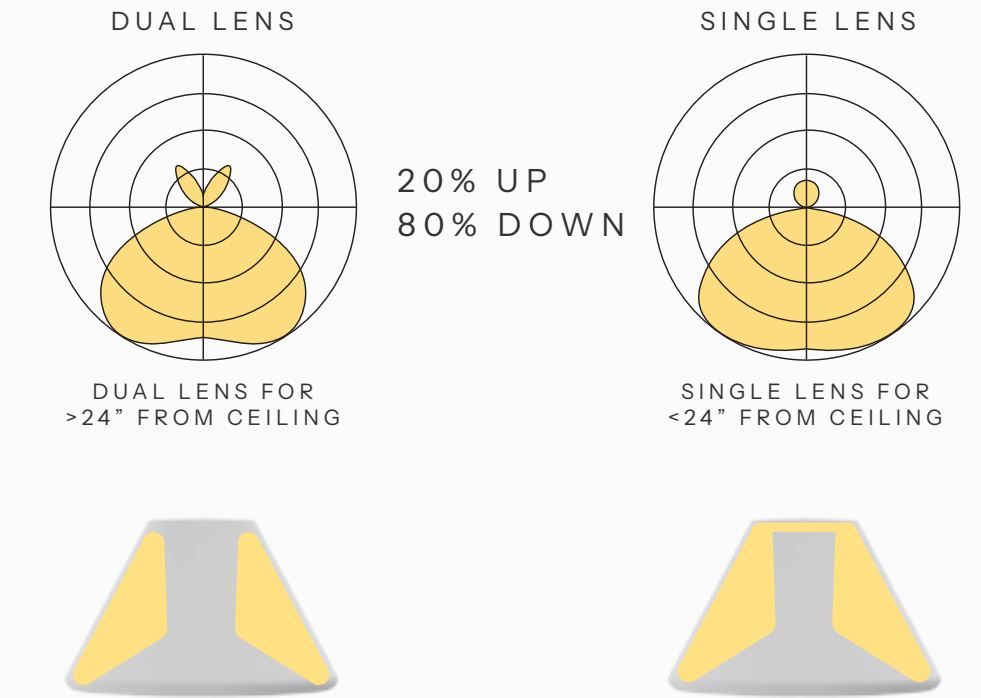

PATTERNS

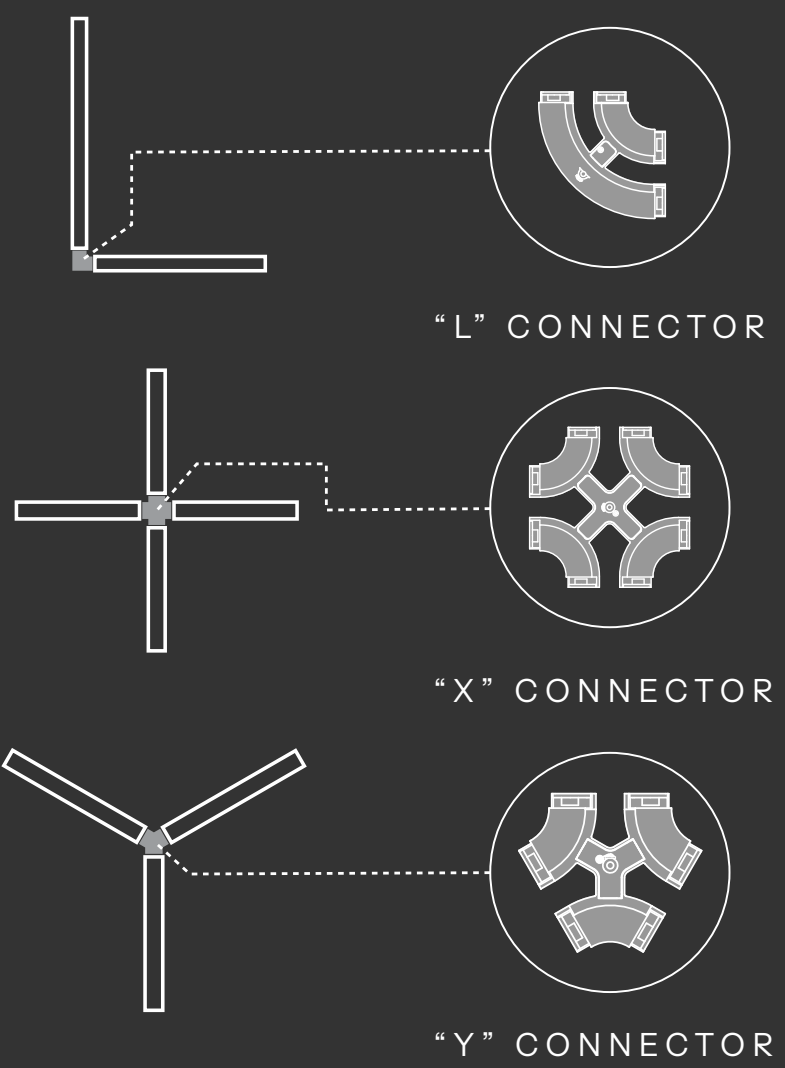

LENGTHS



FEATURES

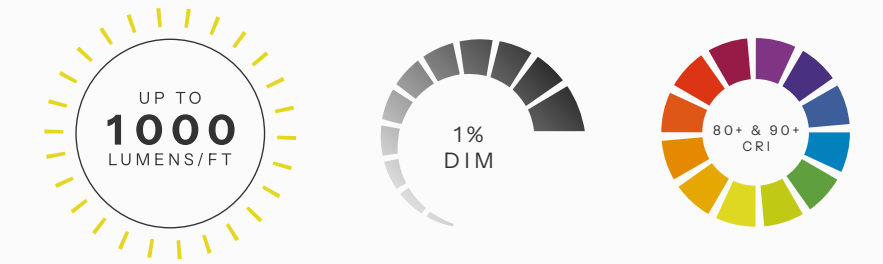

FINISHES



*Colors for representational purpose only. For accurate color please contact the factory for color samples.



SORREL
DOWN

D
DOWN

Sorrel DOWN distributes lighting at 20% uplight/ 80% downlight. Sorrel DOWN is a great solution when task oriented work is the key application need, while allowing for a portion of the light to escape upward to prevent dark ceiling planes.

The Sorrel DOWN is offered with 2 different lensing options: The dual open frame is for application spaces where the mounting application is 24" or greater from the ceiling. A one-piece lens offering, is meant to be used when mounting applications are less than 24" from the ceiling.

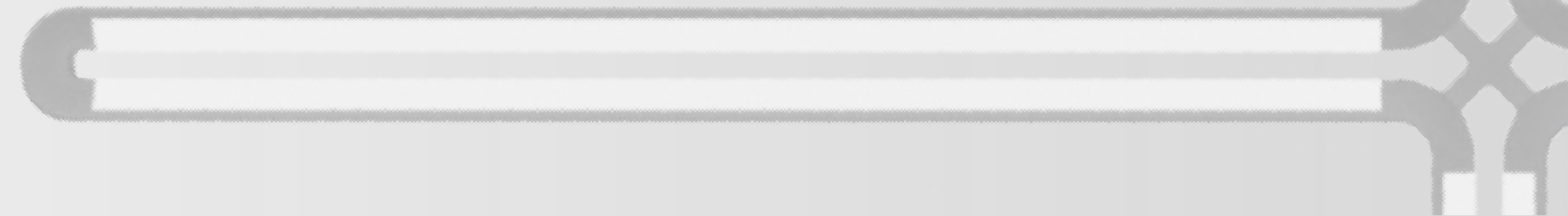

FACTOR

X-CONNECTOR

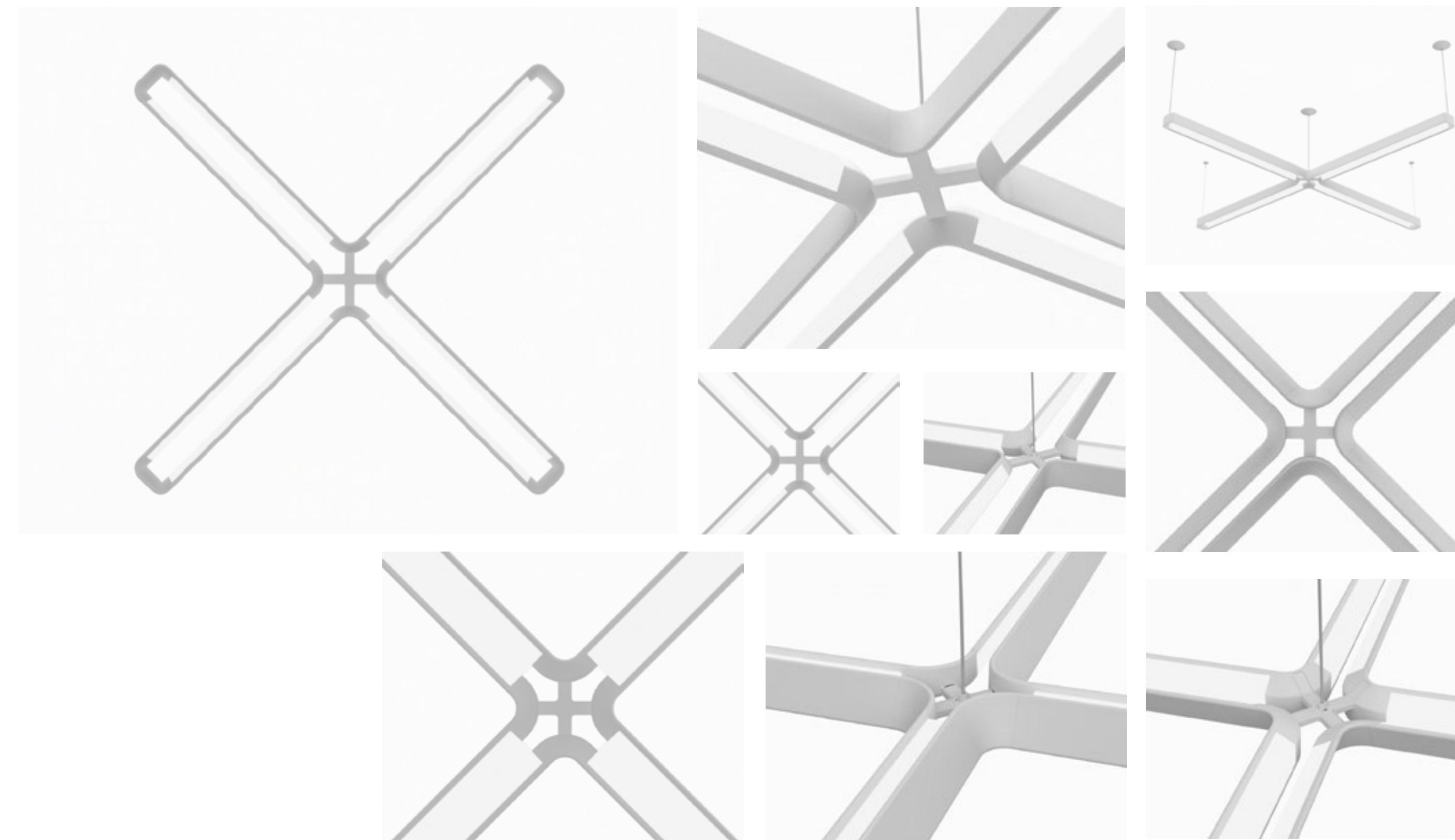

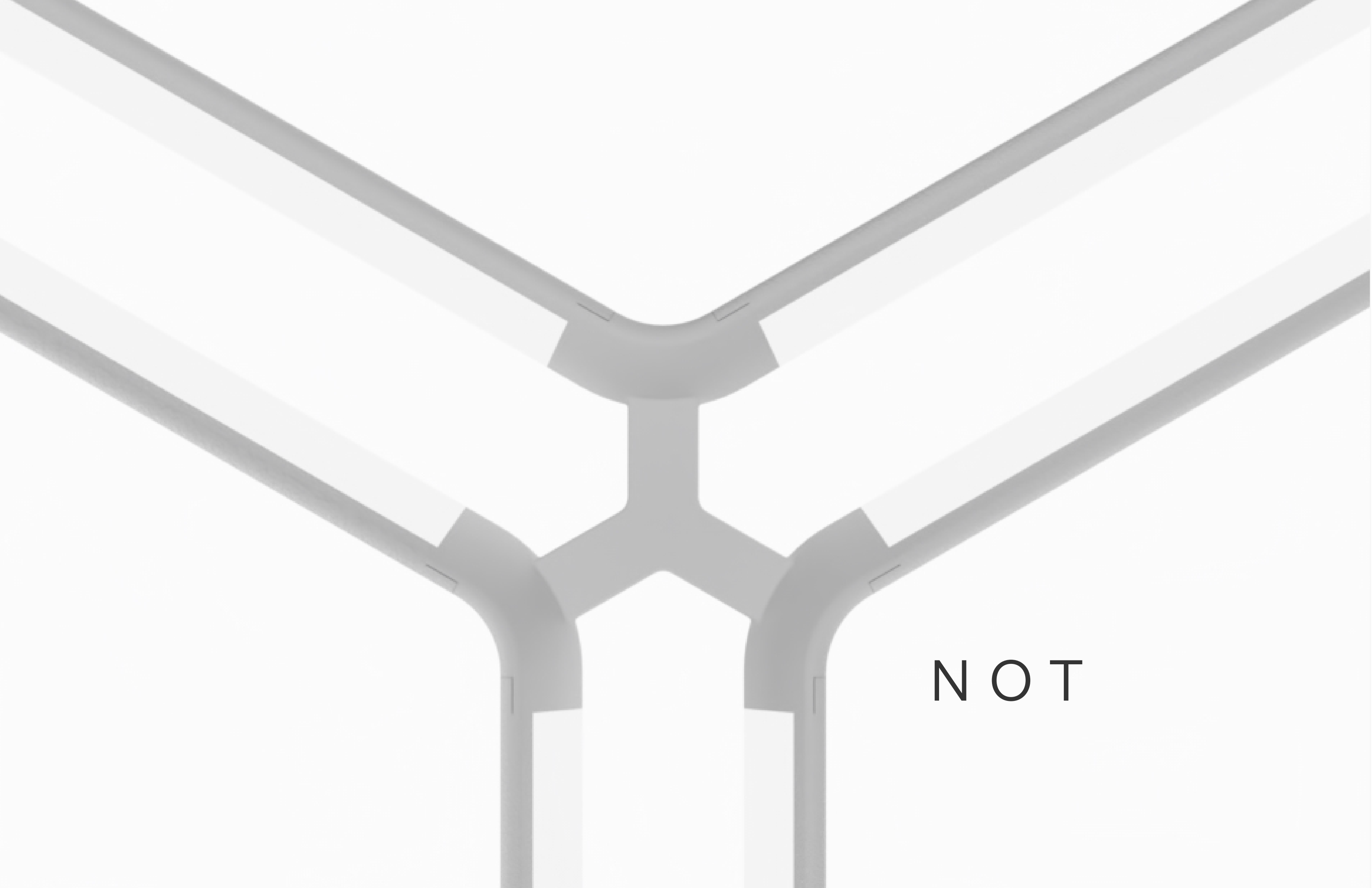

NOT

Y-CONNECTOR

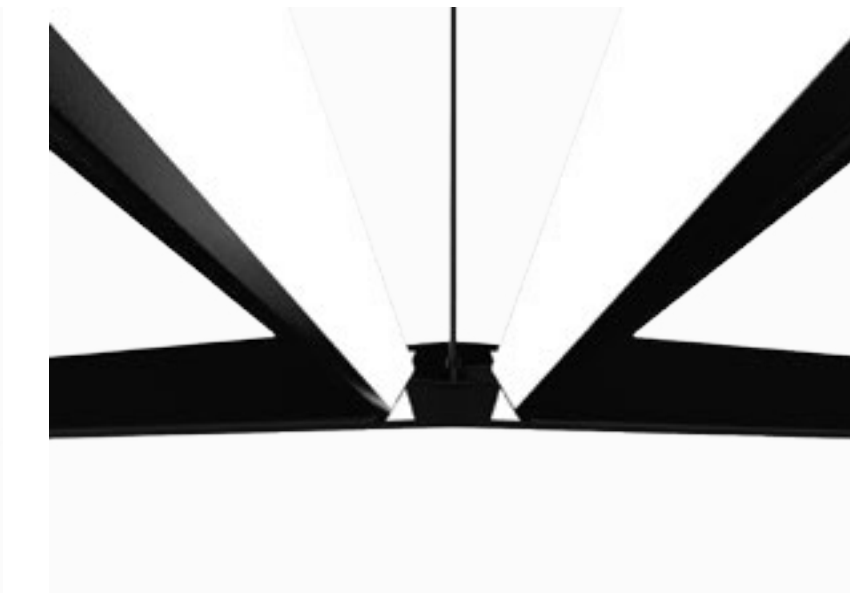
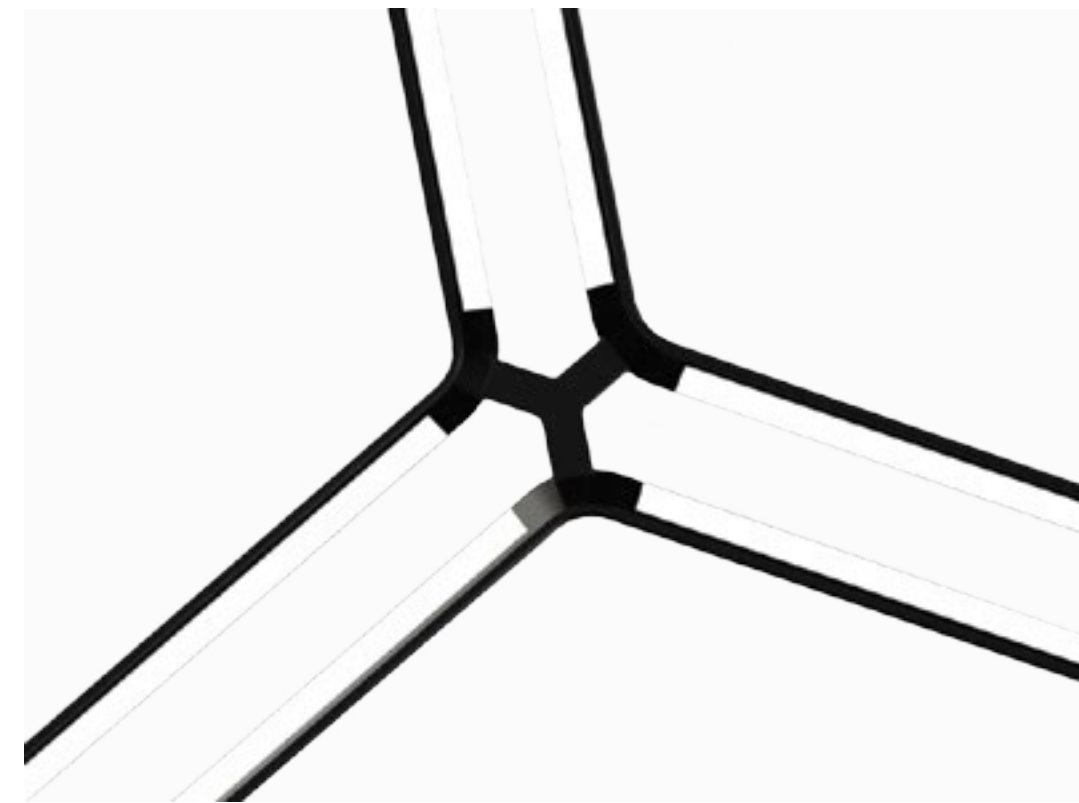

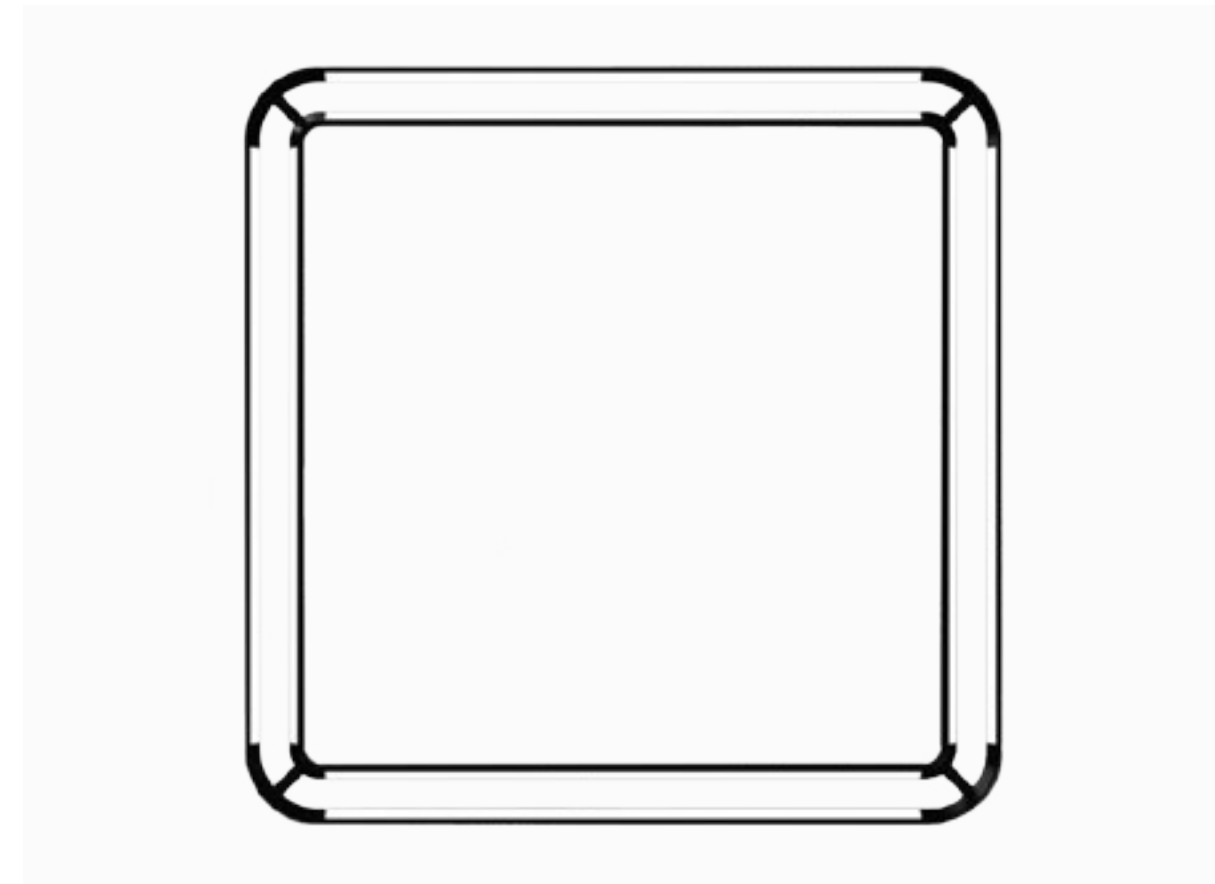
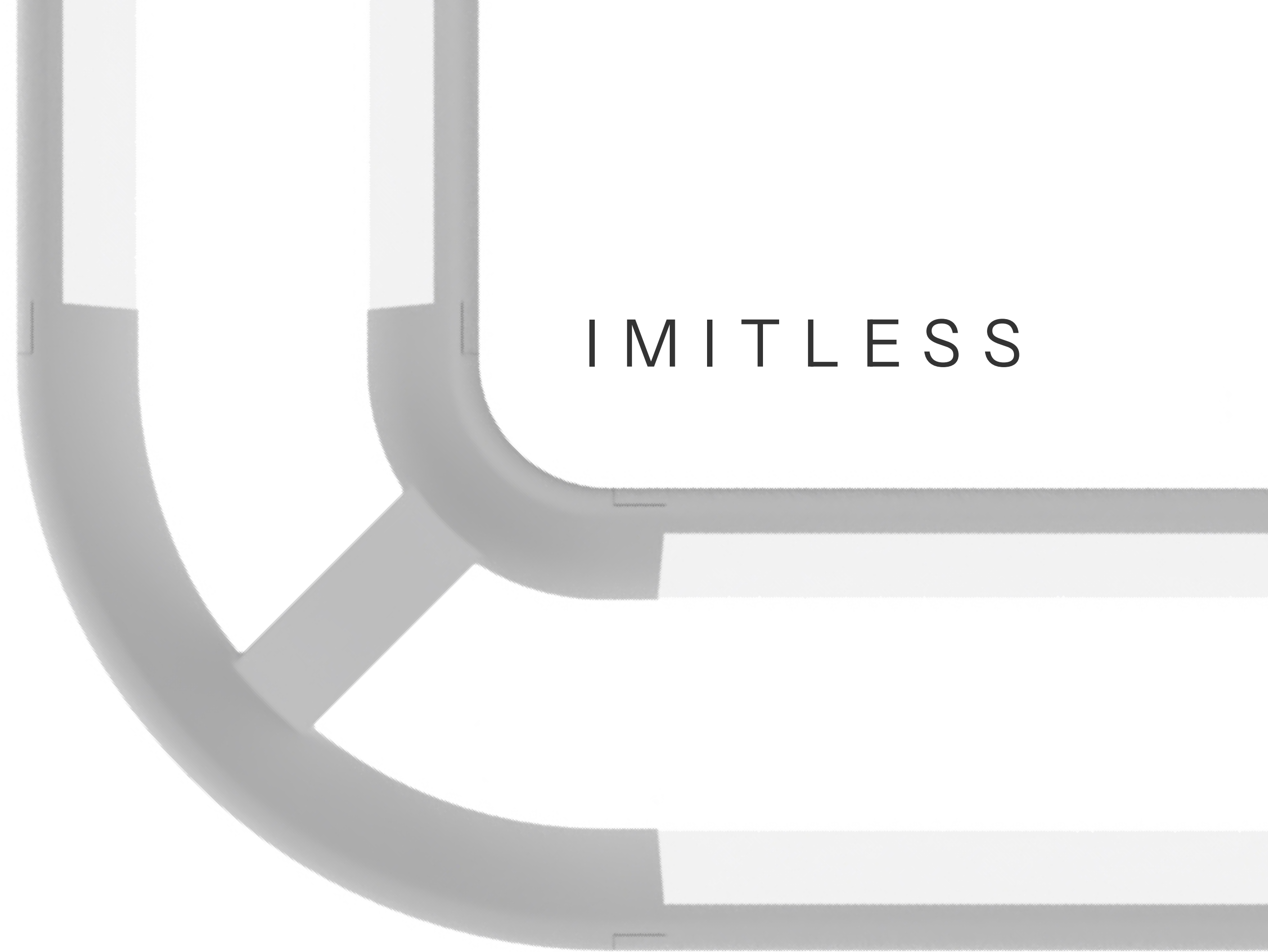

L-CONNECTOR

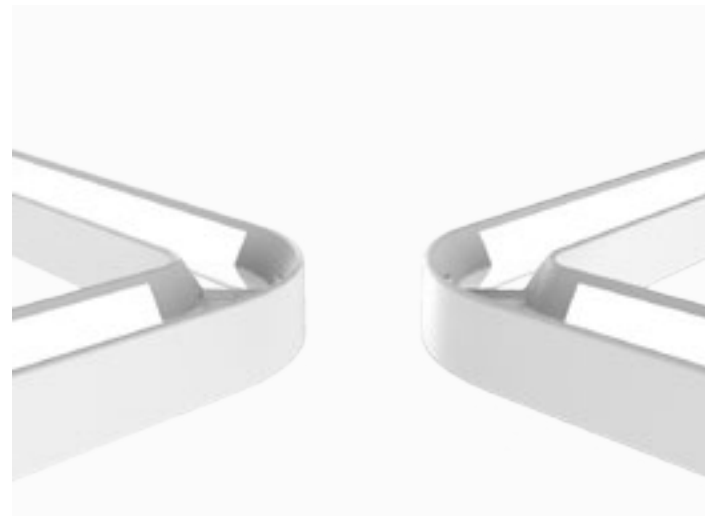

SORREL



P I N N A C L E
ARCHITECTURAL LIGHTING®

3801 Havana St. Denver CO, 80239
Phone: 303.322.5570
www.pinnacle-ltg.com

March 2024
© 2024 Pinnacle Architectural
Lighting®

Specifications and dimensions subject to change without notice. Specification sheets and brochures that appear on pinnacle-ltg.com are the most recent version and supersede all other previously printed or electronic versions.

A brand of  **legrand®**