

Ridge

T5/T5HO & T8 AC - to - ST Mount

Step 1: Power at Ceiling

1. Install 4-octagonal junction box to structure adjacent to power feed mount locations.
2. Attach crossbar to junction box.
3. Run SJT power cord through canopy and into junction box. Secure using provided strain relief.
4. Make necessary power connections.
5. Feed Aircraft cable through coupler, secure canopy to junction using coupler (provided)

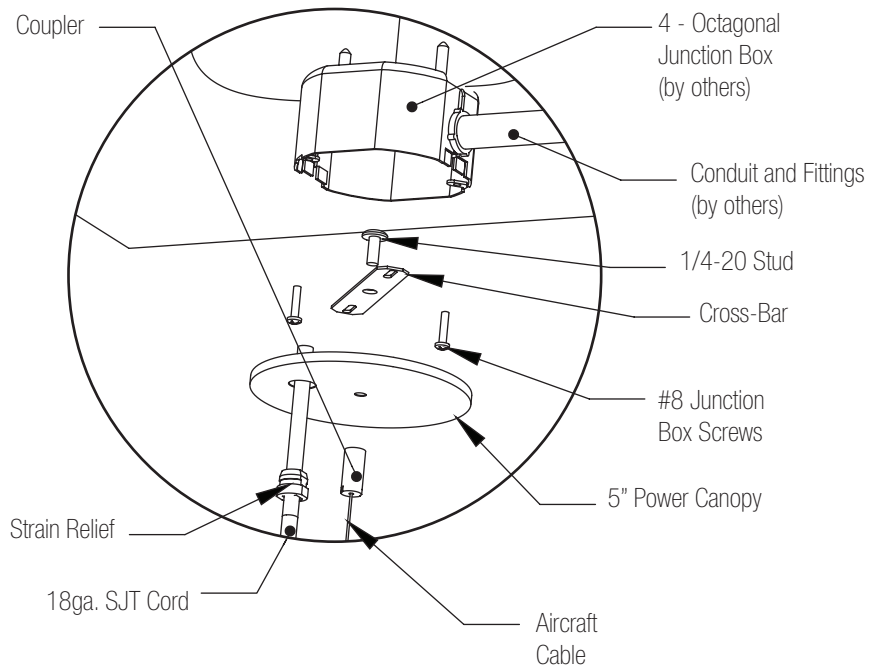
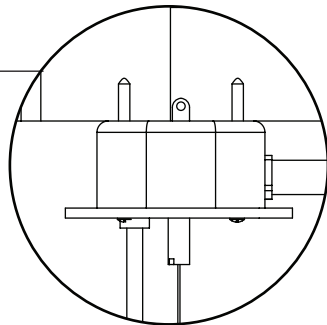

Step 2: Non Power Mount

1. Install 1/4-20 studs to structure at all mounting points (3/4" below ceiling plan.)
2. Feed aircraft cable through coupler (if applicable).
5. Secure coupler assembly to 1/4-20 bolt or stud.

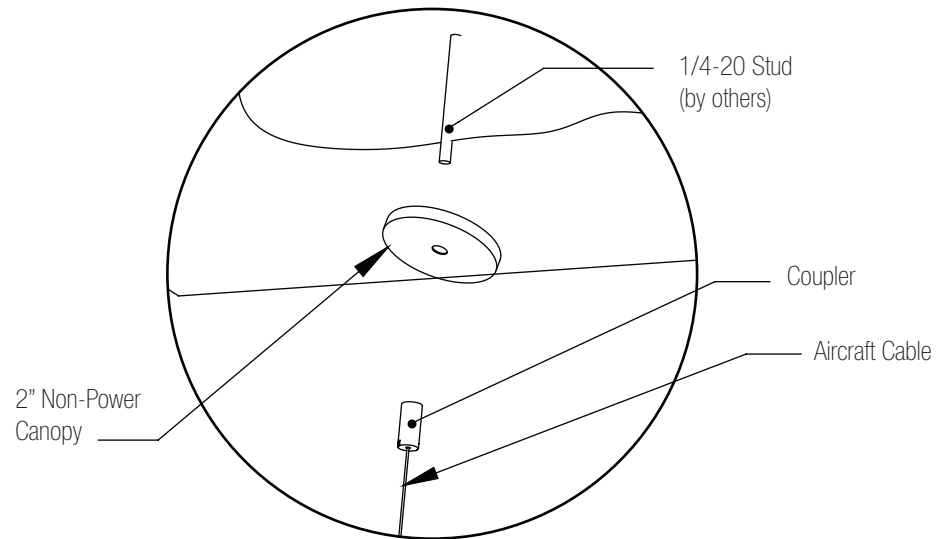
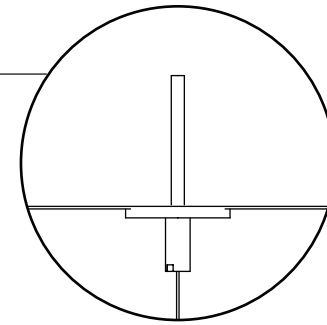

* Stud comes 1/2" Below Ceiling Plane



1. This product must be installed in accordance with applicable installation and electrical codes by a professional familiar with the construction and operation of the product.
2. Minimum 90°C supply conductors
3. All electrical connections must be performed by a certified electrician to applicable local and national electrical codes.
4. Do not assemble fixture together on ground and then install.

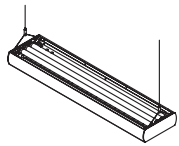

Ridge

T5/T5HO & T8 AC - to - ST Mount

Step 3: AC Mounting

1. Slide cable ends into mounting slots.
2. Slide aircraft cable through top gripper.
3. Adjust gripper side-to-side to level fixture then tighten.
4. Repeat process for subsequent fixture(s).
And re-level previous fixtures as necessary.

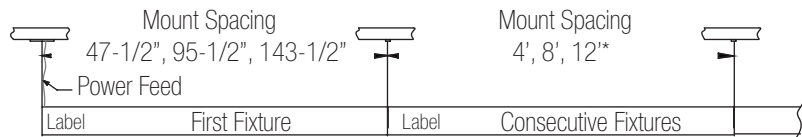
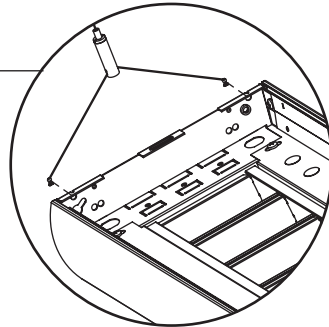

First fixture supported by two(2) mounts consecutive fixture supported by previous fixture one(1) mount.
*12' fixture length only available for some configurations.

Step 5: Joining Fixtures

1. Install joining kit hardware.
2. Make wiring connections between fixtures, and recess wires into one of the fixtures.
2. Slip adjacent fixture's mounting hardware through the keyhole slots on the end plates.
4. Tighten joining hardware.

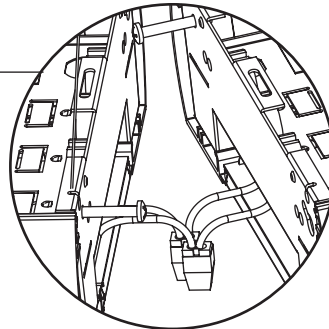

Step 4 : Making the connections

1. Remove K.O.(s)
2. Feed SJT through K.O. and route wires out fixture.
3. Attach white plastic strain relief.
4. Make necessary wiring connections.
5. Ensure all wires are properly matched.

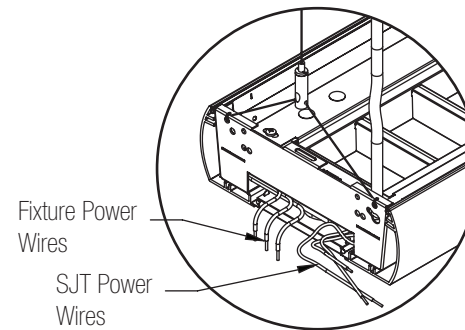
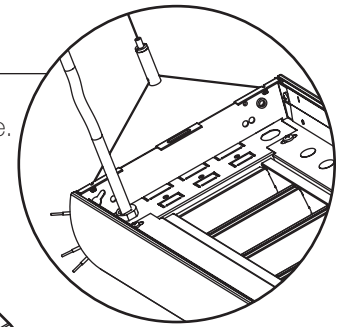

Step 6: Finishing

1. Install end caps.
2. Place against end of fixture and secure using two (2) #8-32 screws.

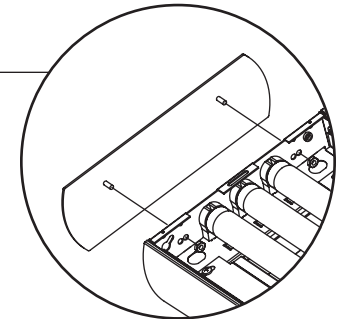

1. This product must be installed in accordance with applicable installation and electrical codes by a professional familiar with the construction and operation of the product.
2. Minimum 90°C supply conductors
3. All electrical connections must be performed by a certified electrician to applicable local and national electrical codes.
4. Do not assemble fixture together on ground and then install.