

Ridge T5/T5HO & T8 ACS - to - JB Mount

Step 1: Power at Ceiling

1. Thread 1/4-20 stud to crossbar for power mounts.
2. Install crossbar to 4-octagonal junction box
3. Run SJT cord through canopy and into junction box, secure with strain relief.
4. Make all necessary wiring connections.
5. Feed aircraft cable through coupler, secure canopy to crossbar bolt using coupler.

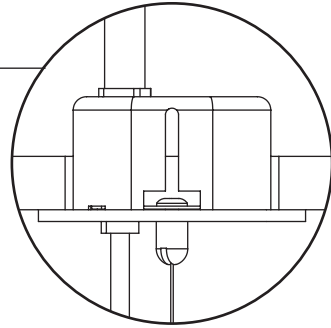

Step 2: Non Power Mount

1. Install 1/4-20 stud for non-power mounts (1/2" below ceiling plane).
2. Feed aircraft cable through coupler.
3. Secure canopy to bolt using coupler.

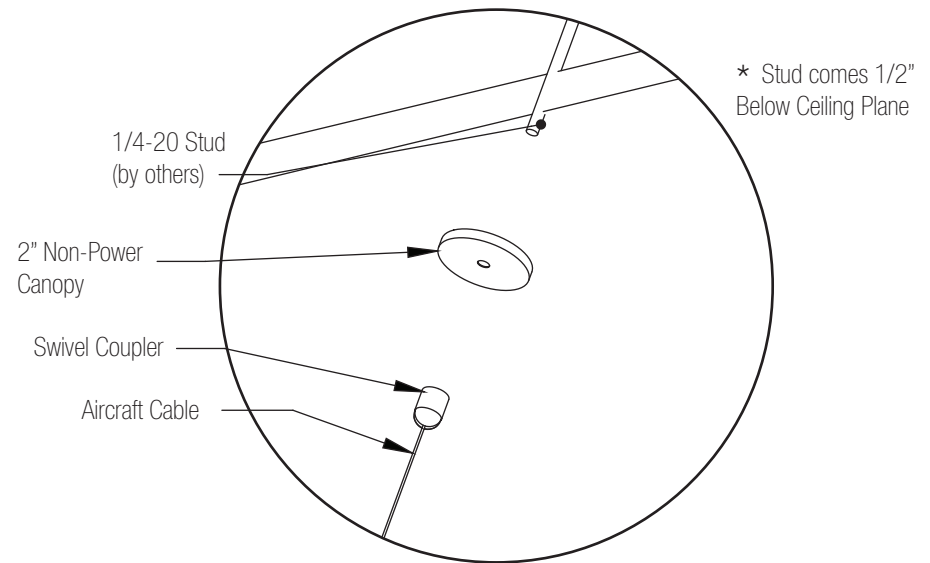
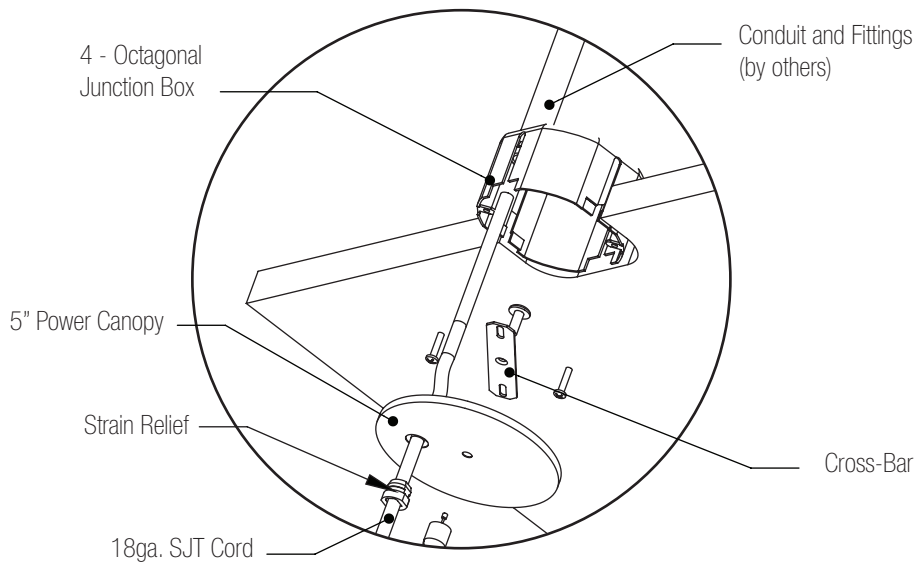
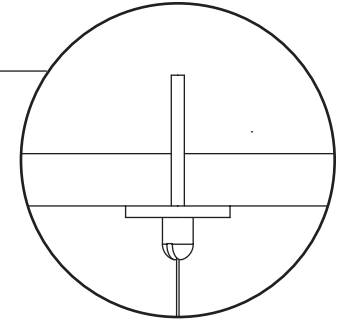

1. This product must be installed in accordance with applicable installation and electrical codes by a professional familiar with the construction and operation of the product.
2. Minimum 90°C supply conductors
3. All electrical connections must be performed by a certified electrician to applicable local and national electrical codes.
4. Do not assemble fixture together on ground and then install.

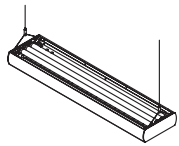

Ridge

T5/T5HO & T8 ACS - to - JB Mount

Step 3: AC Mounting

1. Slide cable ends into mounting slots.
2. Slide aircraft cable through top gripper.
3. Adjust gripper side-to-side to level fixture then tighten.
4. Repeat process for subsequent fixture(s). Re-level previous fixtures as necessary.

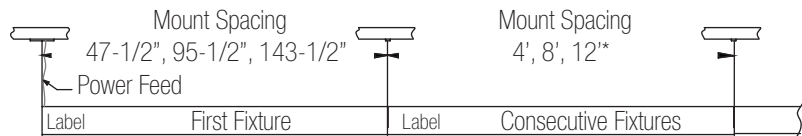
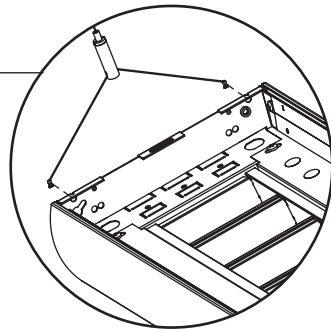

First fixture supported by two(2) mounts consecutive fixture supported by previous fixture one(1) mount.
*12' fixture length only available for some configurations.

Step 5: Joining Fixtures

1. Install joining kit hardware.
2. Make wiring connections between fixtures, and recess wires into one of the fixtures.
2. Slip adjacent fixture's mounting hardware through the keyhole slots on the end plates.
4. Tighten joining hardware.

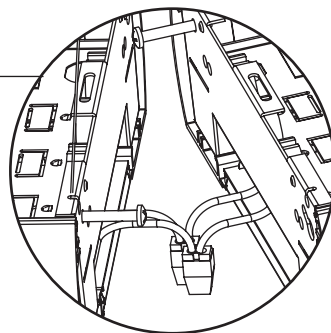

Step 4 : Making the connections

1. Remove K.O.(s)
2. Feed SJT through K.O. and route wires out fixture.
3. Attach white plastic strain relief.
4. Make necessary wiring connections.
5. Ensure all wires are properly matched.

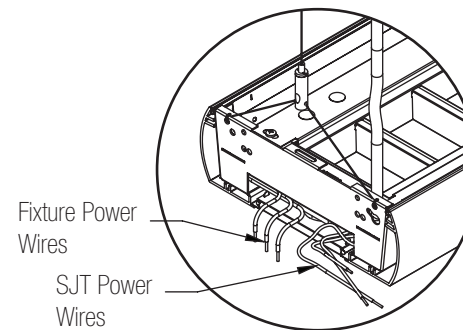
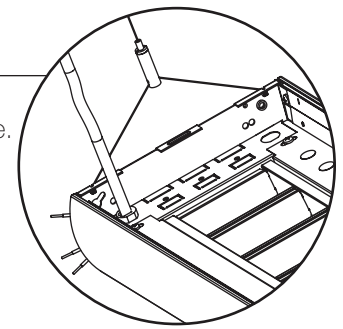

Step 6: Finishing

1. Install end caps.
2. Place against end of fixture and secure using two (2) #8-32 screws.

