

LINERO T5/T5HO & T8 DAC - to - ST Mount

Step 1: Power at Ceiling

1. Install square J-box to structure adjacent to power feed mount locations.
2. Attach crossbar to junction box.
3. Run SJT power cord through canopy and into junction box. Secure using provided strain relief.
4. Make necessary power connections.
5. Feed Aircraft cable through coupler, and gripper and secure canopy to junction using coupler.

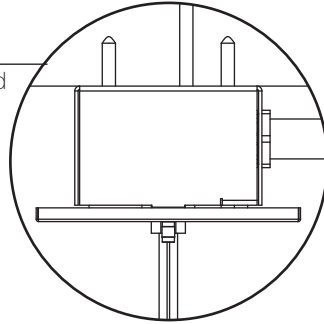

Step 2: Non Power Mount

1. Install square J-box to structure.
2. Attach crossbar to junction box.
3. Feed Aircraft cable through coupler, and gripper and secure canopy to junction using coupler.

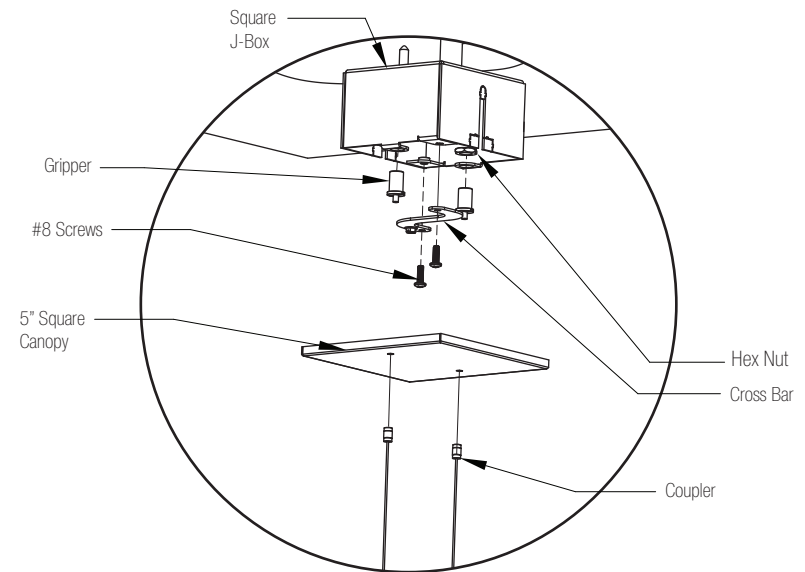
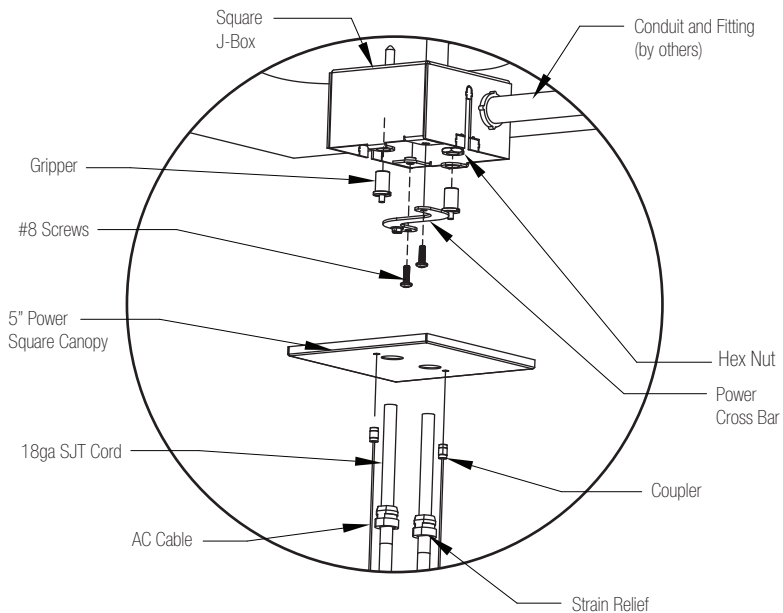
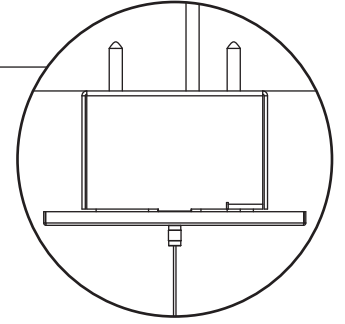

1. This product must be installed in accordance with applicable installation and electrical codes by a professional familiar with the construction and operation of the product.
2. Minimum 90°C supply conductors
3. All electrical connections must be performed by a certified electrician to applicable local and national electrical codes.
4. Do not assemble fixture together on ground and then install.

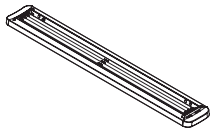

LINERO T5/T5HO & T8 DAC - to - ST Mount

Step 3: DAC Mounting

1. Slide cable ends into mounting slots.
2. Repeat process for subsequent fixture(s).
And re-level previous fixtures as necessary.

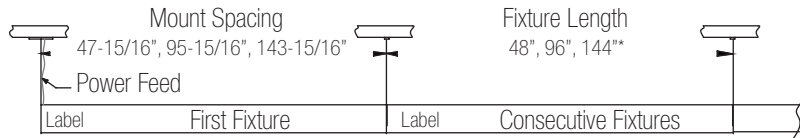
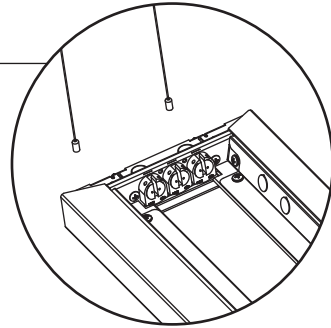

First fixture supported by two (2) mounts consecutive fixture supported by previous fixture one (1) mount.
*144" fixture length only available for Linero 8 configurations.

Step 5: Joining Fixtures

1. Make wiring connections between fixtures, and recess wires into one of the fixtures.
2. Feed joining hardware through the slot until you reach the PEM nut.
4. Tighten joining hardware.

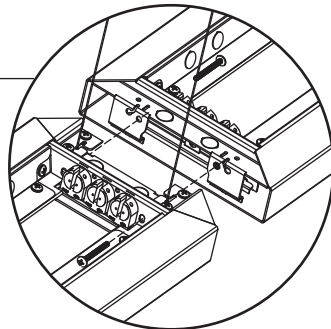

Step 4: Making the connections

1. Remove K.O.(s) and attach plastic bushing.
2. Feed SJT through K.O. and route wires out fixture.
3. Attach metal strain relief.
4. Make necessary wiring connections.
5. Ensure all wires are properly matched.

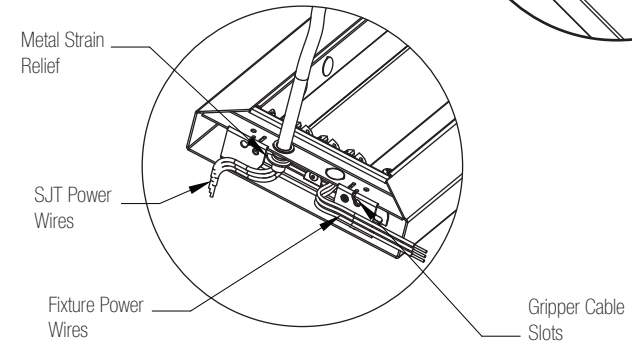
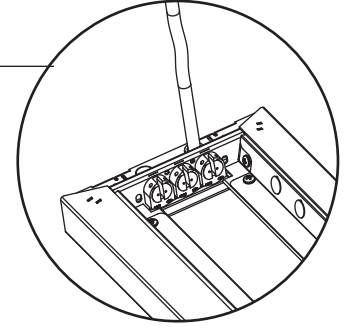

Step 6: Finishing

1. Install end caps.
 2. Place against end of fixture and secure using two (2) #8-32 screws.
 3. Install joining covers.
- (Note: Joining cover for continuous runs, Linero 6)**

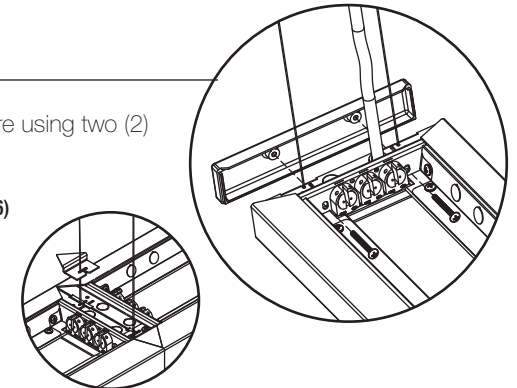

1. This product must be installed in accordance with applicable installation and electrical codes by a professional familiar with the construction and operation of the product.
2. Minimum 90°C supply conductors
3. All electrical connections must be performed by a certified electrician to applicable local and national electrical codes.
4. Do not assemble fixture together on ground and then install.