

LINERO T5/T5HO & T8 DAC - to - Grid Mount

Step 1: Power at Ceiling

1. Install junction box onto T-Bar ceiling. Tie box off to structure. Install conduit from building power.
2. Thread 1/4-20 stud to crossbar for power mounts. Install crossbar to junction box.
3. Run SJT cord through canopy, make necessary power connections, secure using strain relief.
4. Feed aircraft cable through coupler.
5. Secure canopy to crossbar bolts using aircraft cable coupler.

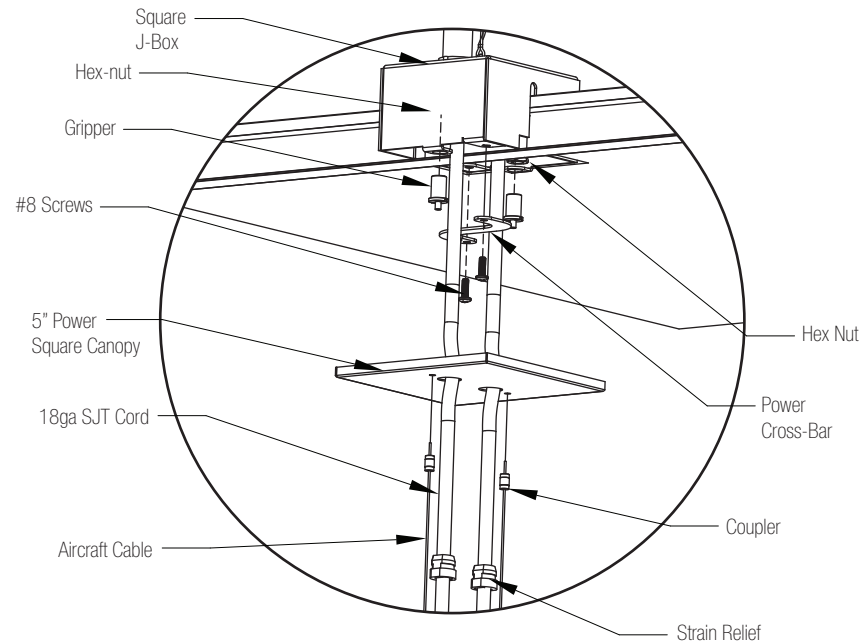
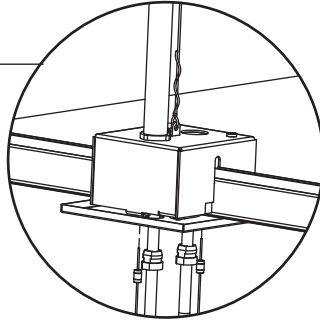

Step 2: Non Power Mount

1. Install IDS clips for non-power mounts. Tie off to structure.
2. Feed aircraft cable through coupler.
3. Secure canopy to IDS clip using aircraft cable coupler.

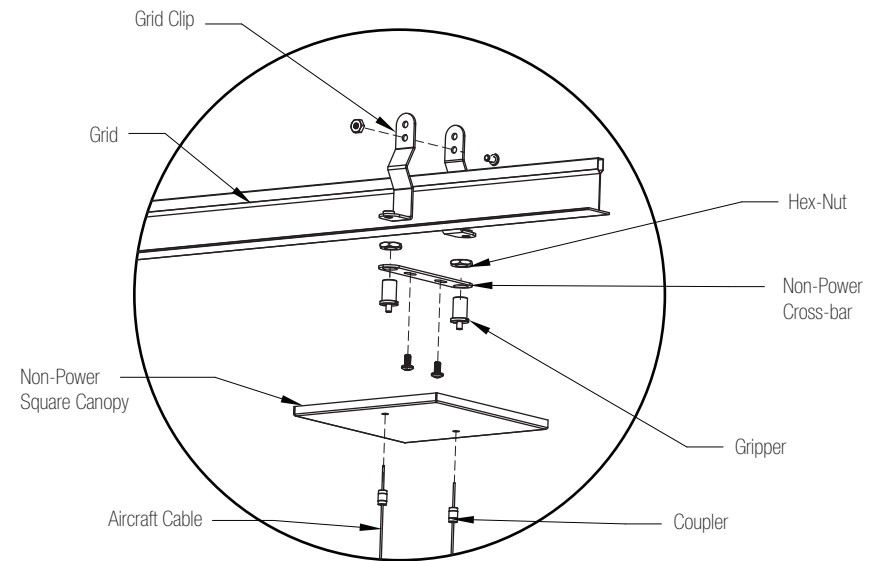
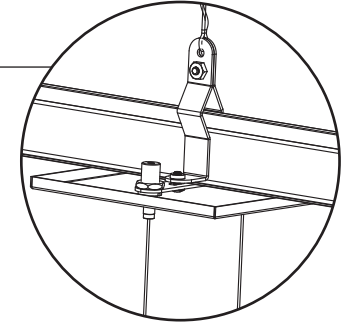

1. This product must be installed in accordance with applicable installation and electrical codes by a professional familiar with the construction and operation of the product.
2. Minimum 90°C supply conductors
3. All electrical connections must be performed by a certified electrician to applicable local and national electrical codes.
4. Do not assemble fixture together on ground and then install.

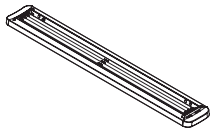

LINERO T5/T5HO & T8 DAC - to - Grid Mount

Step 3: AC Mounting

1. Slide cable ends into mounting slots.
2. Repeat process for subsequent fixture(s).
And re-level previous fixtures as necessary.

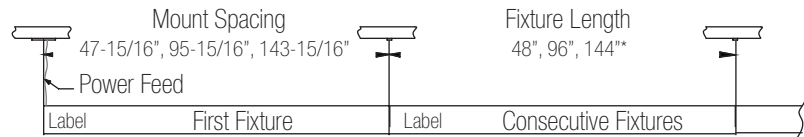
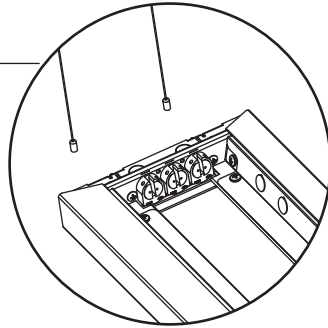

First fixture supported by two (2) mounts consecutive fixture supported by previous fixture one (1) mount.
*144" fixture length only available for Linero 8 configurations.

Step 5: Joining Fixtures

1. Make wiring connections between fixtures, and recess wires into one of the fixtures.
2. Feed joining hardware through the slot until you reach the PEM nut.
4. Tighten joining hardware.

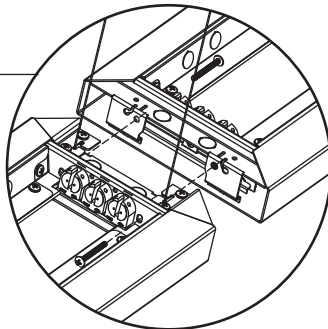

Step 4: Making the connections

1. Remove K.O.(s) and attach plastic bushing.
2. Feed SJT through K.O. and route wires out fixture.
3. Attach metal strain relief.
4. Make necessary wiring connections.
5. Ensure all wires are properly matched.

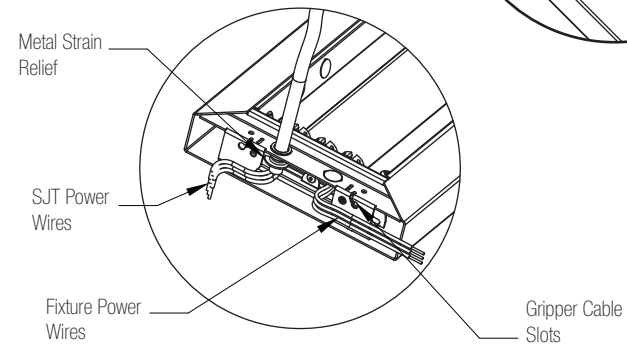
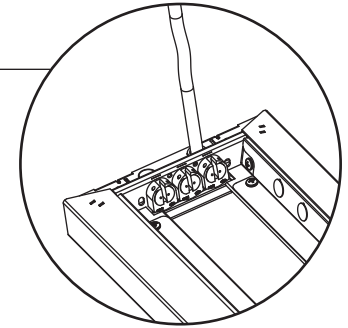

Step 6: Finishing

1. Install end caps.
 2. Place against end of fixture and secure using two (2) #8-32 screws.
 3. Install Joining cover.
- (Note: Joining cover for continuous runs, Linero 6)

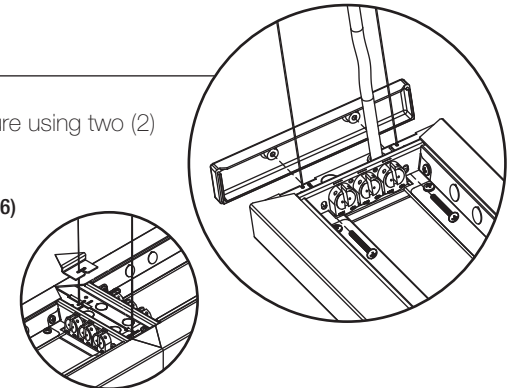

1. This product must be installed in accordance with applicable installation and electrical codes by a professional familiar with the construction and operation of the product.
2. Minimum 90°C supply conductors
3. All electrical connections must be performed by a certified electrician to applicable local and national electrical codes.
4. Do not assemble fixture together on ground and then install.