

# LINERO

## Corner Install Instructions

### Corner

1. Remove corner wire cover.
2. Attach corner to one of the fixtures prior to installation.
3. Make necessary wire connections within corner enclosure.
4. Install joining hardware, slip adjacent fixtures hardward through slots.
5. Tighten joining hardware, and re-attach wire cover.

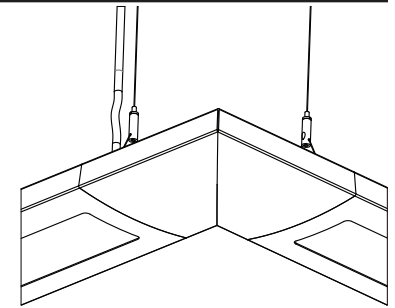
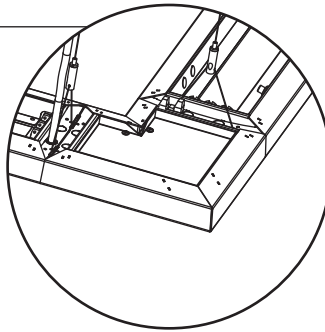

\* Corners should be used to join fixtures together and not act as mounting location.

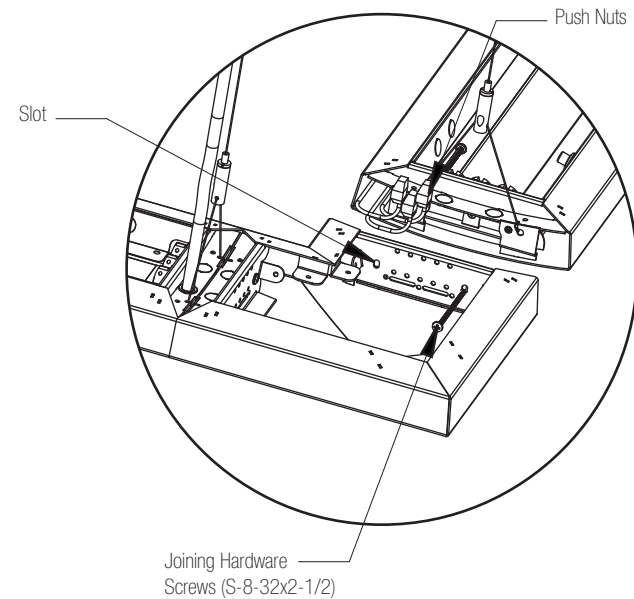
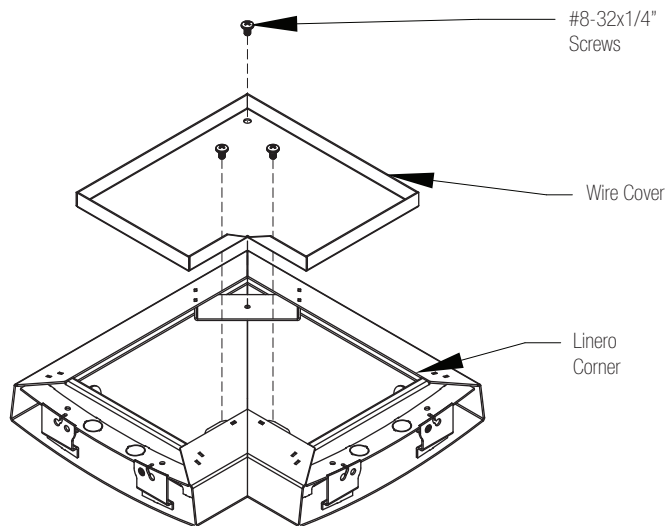

1. This product must be installed in accordance with applicable installation and electrical codes by a professional familiar with the construction and operation of the product.
2. Minimum 90°C supply conductors
3. All electrical connections must be performed by a certified electrician to applicable local and national electrical codes.
4. Do not assemble fixture together on ground and then install.

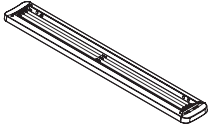

# LINERO

## Corner Install Instructions

Linero 6  
L Corner

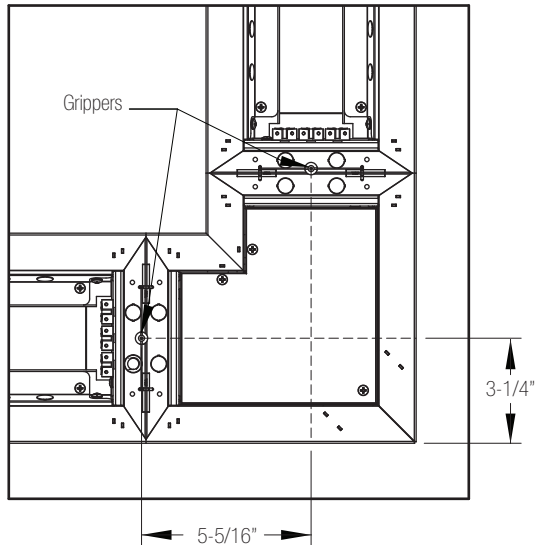

Linero 6 Curved  
L Corner

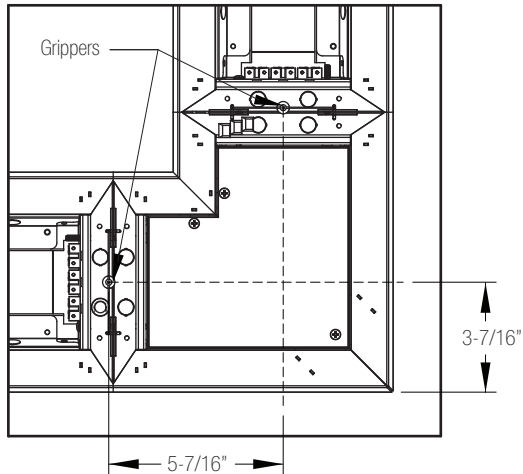

Linero 8  
L Corner

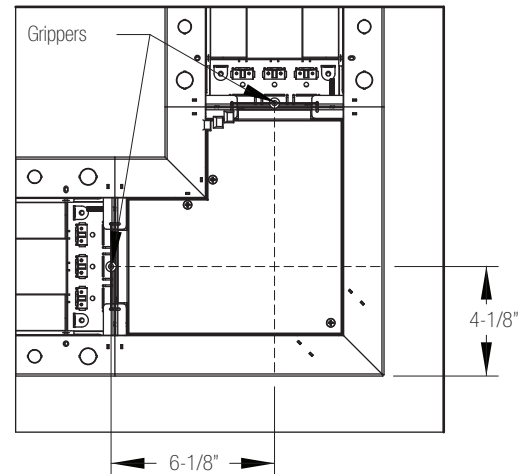

1. This product must be installed in accordance with applicable installation and electrical codes by a professional familiar with the construction and operation of the product.
2. Minimum 90°C supply conductors
3. All electrical connections must be performed by a certified electrician to applicable local and national electrical codes.
4. Do not assemble fixture together on ground and then install.