

EDGE4 T5/T5HO/T8 Spackle Flange Installation

*** DO NOT SCREW INTO SIDE OF HOUSING ***
DO NOT REMOVE CROSS BRACKETS
UNTIL FIXTURE IS INSTALLED

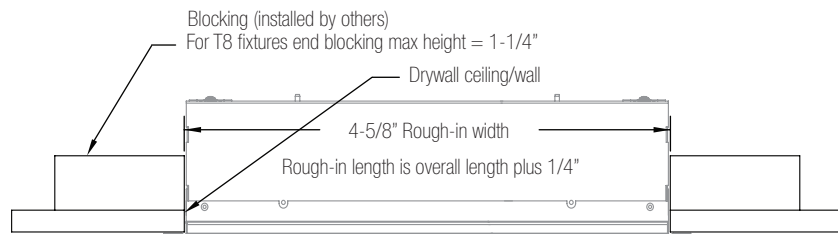

Opening can not be smaller than 4-1/2". An "End Trim" may be used as a gauge for ensuring minimum width.
 Always install lenses during installation and louvers AFTER ALL finishing work has been completed.

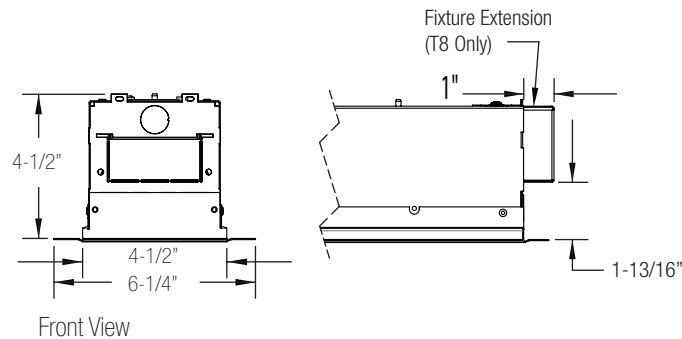
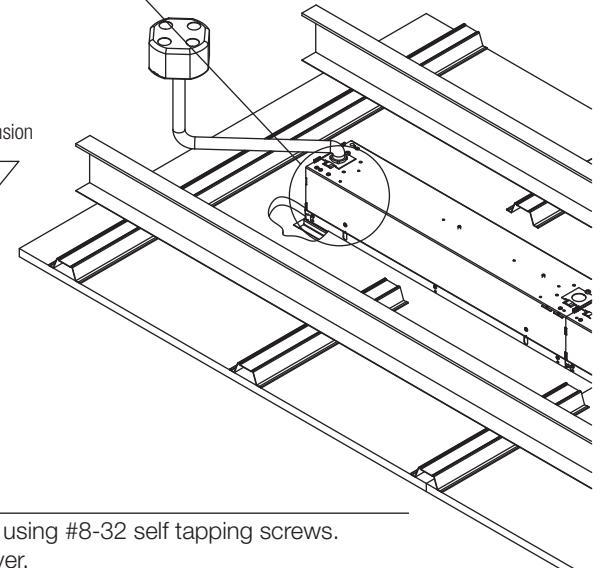
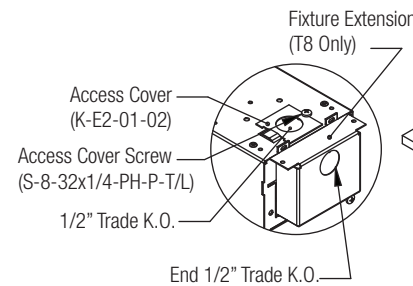
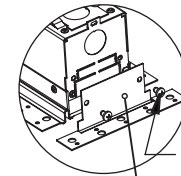
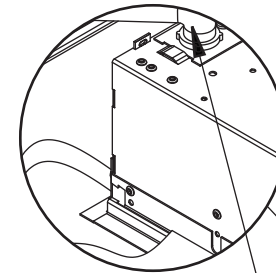

Step 1: Layout/ Dimensions

1. Layout fixtures and blocking locations.
2. Layout and install junction boxes and whip out below ceiling level.
3. Install blocking to structure using rough in dimensions.
4. Install ceiling material.
5. Cut out the fixture/row rough-in.

Step 2: Making the Connections

1. Attach end trim to end fixtures using #8-32 self tapping screws.
2. Remove applicable access cover.
3. Attach conduit to access cover using 1/2" trade fittings.
4. Make electrical connections inside fixture.
5. Replace access cover.



1. This product must be installed in accordance with applicable installation and electrical codes by a professional familiar with the construction and operation of the product.
2. Minimum 90°C supply conductors
3. All electrical connections must be performed by a certified electrician to applicable local and national electrical codes.
4. Fixtures must be mounted directly to structure.

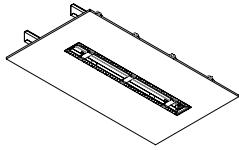

EDGE4 T5/T5HO/T8 Spackle Flange Installation

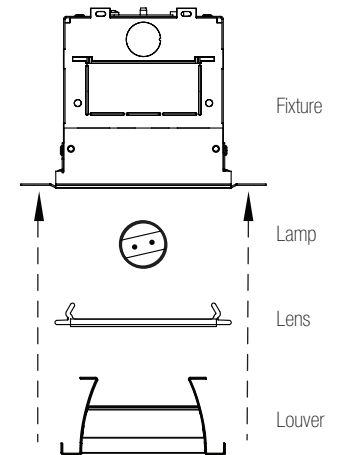
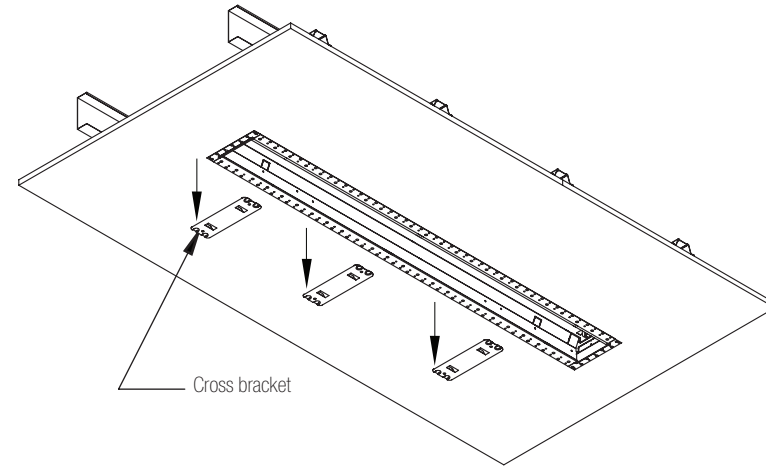
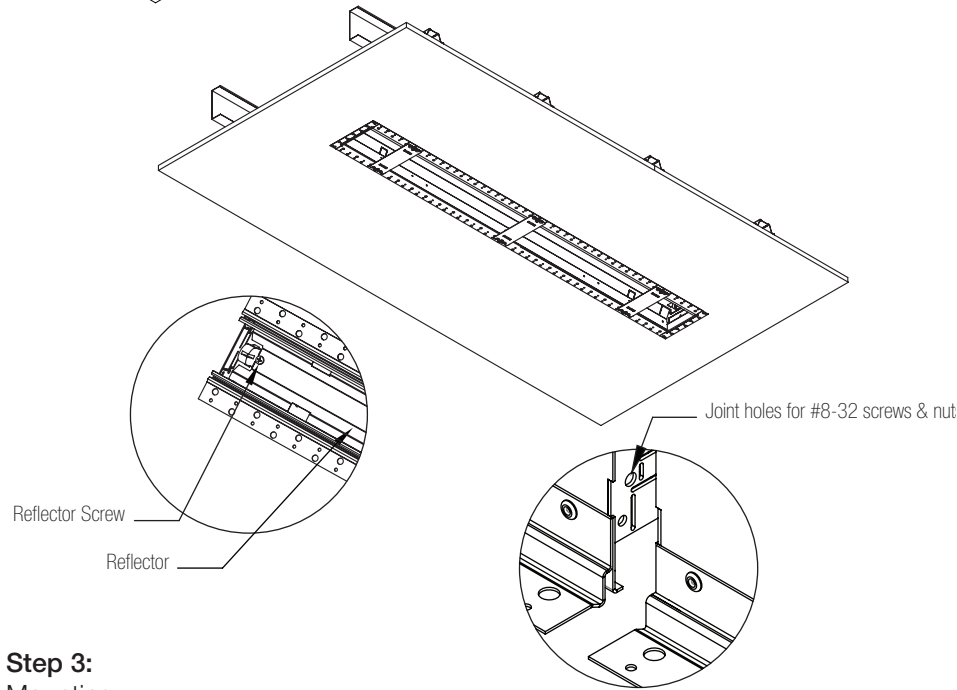

Step 3: Mounting

1. Position fixture in roughed and blocked in opening.
2. Mount the fixture in place using at least 1 screw approximately every 6" along the length of the fixture and two on each end flange.
3. Once mounted into the wall, remove cross brackets and discard.
4. Remove reflector to wire to building power.

For Continuous Runs

1. Remove end knock-outs between fixtures.
2. Lift and rotate fixtures into place secure fixture with joining hardware.
3. Mount fixture by screwing through the holes in the flange to the wood blocking. Using at least one screw approximately every 6" along all sides.
4. Remove cross brackets and dispose.
5. Remove reflector and make necessary wiring connections between fixtures.
6. Secure fixtures together using supplied #8-32 screws and nuts.

Step 4: Finishing

1. Replace reflector
2. Install lamp(s)
3. Install lens or louver.

1. This product must be installed in accordance with applicable installation and electrical codes by a professional familiar with the construction and operation of the product.
2. Minimum 90°C supply conductors
3. All electrical connections must be performed by a certified electrician to applicable local and national electrical codes.
4. Fixtures must be mounted directly to structure.



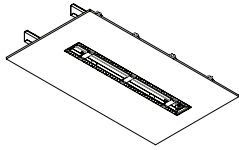

EDGE4 T5/T5HO/T8 Spackle Flange Installation

Row Configuration Notes:

EOR/IND fixtures are less than nominal in length.

Row configurations shown are standard.

Non-standard row configurations may be specified for your project and will be shown on a project submittal. Overall row lengths and rough-in lengths will be shown on the submittal. Standard rows for project typically do not have submittal drawings.

All fixtures are modular and may be used in any location (except special circuits)

Special circuit fixtures should be installed in the locations specified.

In general, installation is assumed to use the largest fixture first, followed by the next largest, etc.

Add 1/4" to overall row length for rough-in.

Battery fixtures have test switch and indicator light remoted (conduit and J-Box by others).

All fixtures through-wired for specified circuits. Quick connects provided between fixtures.

Nominal Fixture Length (bold) Versus Actual Length (T5 & T8)

Fixture	2'	3'	4'	6'	8'
BOR/INT	XX	XX	48"	72"	96"
EOR/IND	23"	35"	47"	71"	95"

Note:

BOR - Beginning of Run
INT - Intermediate Fixture
EOR - End of Run
IND - Individual Fixture

Row Configuration Chart

Nominal Row Length	Actual Row Length	Fixture Units in Row Configuration
2 ft	1' 11"	23'
3 ft	2' 11"	35'
4 ft	3' 11"	47'
5 ft	4' 10" †	36' + 23'
6 ft	5' 11"	71'
7 ft	6' 11"	48' + 35'
8 ft	7' 11"	95'
9 ft	8' 11"	72' + 35'
10 ft	9' 11"	72' + 47'
11 ft	10' 11"	96' + 35'
12 ft	11' 11"	96' + 47'
13 ft	12' 11"	72' + 48' + 35'
14 ft	13' 11"	96' + 71'
15 ft	14' 11"	96' + 48' + 35'
16 ft	15' 11"	96' + 95'
17 ft	16' 11"	96' + 72' + 35'
18 ft	17' 11"	96' + 72' + 47'
19 ft	18' 11"	96' + 96' + 35'
20 ft	19' 11"	96' + 96' + 47'
21 ft	20' 11"	96' + 72' + 48' + 35'
22 ft	21' 11"	96' + 96' + 71'
23 ft	22' 11"	96' + 96' + 48' + 35'
24 ft	23' 11"	96' + 96' + 95'
25 ft	24' 11"	96' + 96' + 72' + 35'

† 5' fixture uses extended end trim to sit on grid.

Fixtures are manufactured so that the Fixture Label (located on reflector) is closest to the start of the row. Subsequent fixtures are installed with the label closest to the previous fixture. (Build the row from left-to-right. Install each fixture with label facing left.)

1. This product must be installed in accordance with applicable installation and electrical codes by a professional familiar with the construction and operation of the product.
2. Minimum 90°C supply conductors
3. All electrical connections must be performed by a certified electrician to applicable local and national electrical codes.
4. Fixtures must be mounted directly to structure.



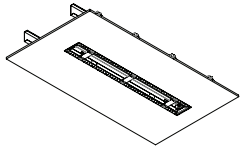

EDGE Snap In Lens Lensing detail sheet

Lens Installation

1. Begin at one end of the fixture and insert lens into appropriate position where it will snap into place.
2. Gradually insert the lens along the length of the fixture, snapping it into place as you go.
3. If at any point the lens becomes difficult to insert press slightly into the center of the lens in order to allow for it to flex, temporarily decreasing the width of the lens.

Lens Removal

1. Insert a rigid object approx. 1/16" thick, such as a quarter, into the edge between the lens and the fixture, approx. 1-2" from the end of the lens. (6" for regress lens)
2. Using said object, gently pry lens away from fixture until it is released from the mounting edge.
3. Once the section is released, start at one end of the fixture and pull the lens out of the fixture.

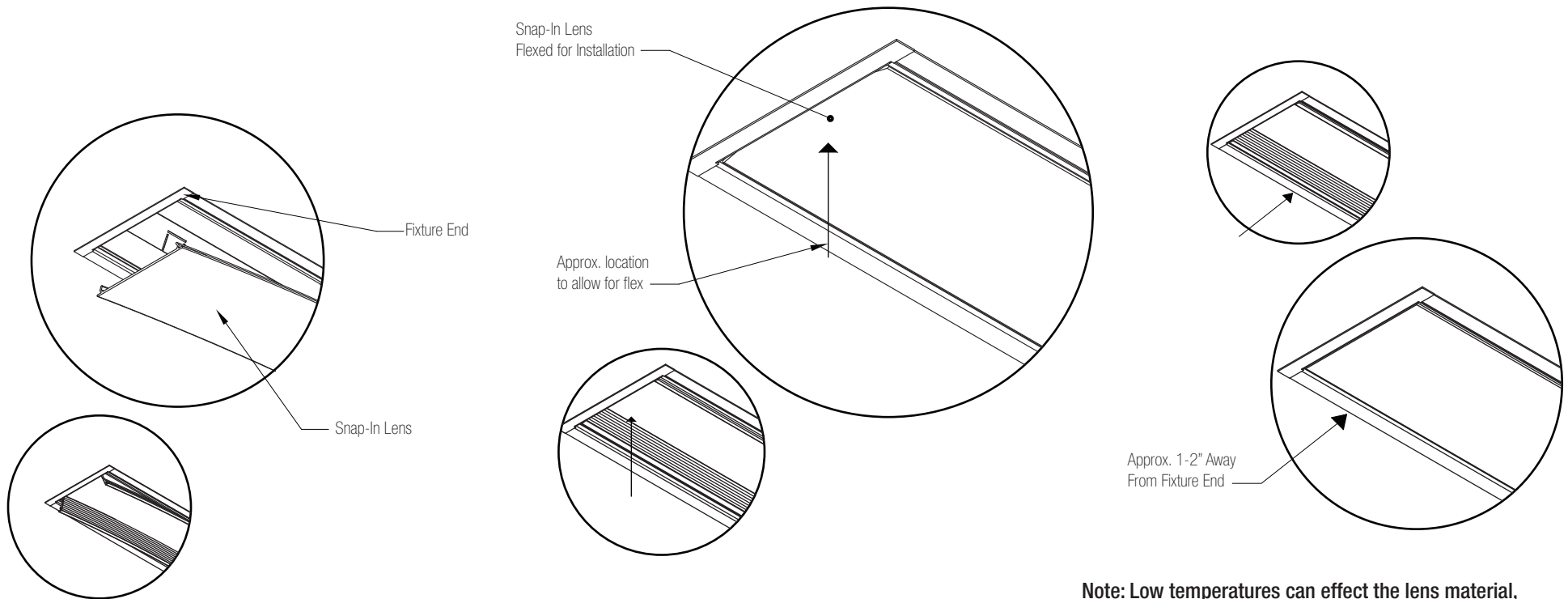

Note: Low temperatures can effect the lens material, making it brittle. Please allow the lenses to warm to room temperature before installation.